



Boyd-Scott Graduate Research Award  
**OFFICIAL ENTRY FORM**

**STUDENT INFORMATION**

<b>Name</b>	Magni Hussain	<b>ASABE Member #</b>	1059015
<b>Mailing Address</b>	_____	<b>Email Address</b>	_____
<b>Research Paper Title</b>	Green Fruit Removal Dynamics for Development of Robotic Green Fruit Thinning End-Effector		
<b>M.S. or Ph.D.</b>	Ph.D.	<b>Expected Date of Graduation (month/year)</b>	8/2023

I hereby attest that the information I have provided in this entry form is true and I meet ALL eligibility requirements for the Graduate Research Award Competition. I have read and understood the rules for the competitions. The paper I am submitting is based on work completed in partial fulfillment of the requirements for the M.S. or Ph.D. degree in Biological/Agricultural Engineering or other closely related engineering graduate degree.

Student's Name Magni Hussain

Date 3/14/2023

**GRADUATE PROGRAM INFORMATION**

<b>Major Professor's Name</b>	Dr. Long He	<b>Major Professor's Email Address</b>	luh378@psu.edu
<b>Dept Head's Name</b>	Dr. Suat Irmak	<b>Dept Head's Email Address</b>	sfi5068@psu.edu
<b>Department Name</b>	Agricultural and Biological Engineering		
<b>University Name</b>	Pennsylvania State University		

**MAJOR PROFESSOR AND DEPARTMENT HEAD ENDORSEMENTS**

I attest that the student named above is a member of ASABE, was enrolled in a graduate program in our department for at least four months between March 15 of this year and March 15 of the previous year and the paper being submitted is based on research completed for either M.S. or Ph.D. degree.

Major Professor's Name  
Long He Long He

Date  
3/14/2023

Department Head's Name  
Suat Irmak Suat Irmak

Date  
03-14-2023

**Submit an electronic copy of your paper and completed and Official Entry Form in a PDF file and email to the attention of the ASABE Awards Administrator, awards@asabe.org, by March 15.**

# GREEN FRUIT REMOVAL DYNAMICS FOR DEVELOPMENT OF ROBOTIC GREEN FRUIT THINNING END-EFFECTOR

## Highlights

- Pulling and stem-cutting methods were used for measuring the green-fruit removal dynamics.
- A stem-cutting end-effector prototype was designed, developed, and tested for green fruit removal.
- No significant correlation was found between fruit/stem size and the required force for fruit removal.
- The success rate of the stem-cutting end-effector prototype for all experiments was over 90%.

**Abstract.** *Green fruit thinning is one of the most important operations in apple production for obtaining high-quality fruit. Manual thinning is time-intensive, making it impractical for large acreages. Some alternative methods such as chemical and mechanical thinning have greatly improved work efficiency, while both have drawbacks due to non-selective targeting. Robotic green fruit thinning can potentially be as selective as manual thinning. This study developed an effective end-effector for robotic green fruit thinning. Prior to designing the end-effector, a series of fruit removal dynamics tests were conducted to find the forces required for robotic thinning using pulling or stem cutting methods on three different apple cultivars. The overall pulling detachment mean forces were  $24.78 \pm 0.48$  and  $19.91 \pm 0.55$  N when detaching stem from the fruit-end and the spur-end respectively. The average force required for stem cutting was  $33.6 \pm 8.0$  N among the three cultivars. There were no significant differences found between fruit/stem dimensions and the forces required for removal. A stem-cutting end-effector prototype was then developed to conduct fruit removal experiments in field conditions. Two end-effector prototype settings were tested, with one placing the end-effector onto a handheld bar, and the other integrating the end-effector with a six DoF robotic manipulator. The success rates of green fruit removal for all end-effector prototype experiments were over 90%. The end-effector is a core component in an automated green fruit thinning system. Integration with the robotic manipulator also indicated the potential of a robotic green fruit system to remove fruit at different locations and orientations. A machine vision system will be developed and integrated with the end-effector to develop a robotic green fruit thinning system.*

**Keywords.** *Crop load management, robotic thinning, end-effector, apple, fruit removal dynamics.*

## 28 INTRODUCTION

29 The apple crop is a high-value agricultural commodity in the U.S., with an annual production total  
30 of nearly 10 billion pounds, valued at nearly \$3 billion (USDA-NASS, 2020). Green fruit thinning is  
31 the process of discarding excess fruitlets in early summer, mainly to increase the remaining fruit size  
32 and quality, and it is one of the most important aspects of apple production (Vanheems, 2015).  
33 Conventionally, manual fruit thinning selectively removes these unwanted fruits from apple trees.  
34 However, manual thinning is a labor-intensive task, and the shrinking apple production labor force  
35 makes manual thinning economically infeasible. In most cases, manual thinning is used as a follow-up  
36 to chemical thinning or mechanical thinning (Schupp et al., 2008).

37 Chemical fruit thinning has been widely studied on different crops, such as apples, peaches, pears,  
38 and olives (Einhorn & Arrington, 2018; Looney, 2018; Giovanaz et al., 2016; Fernández et al., 2015).  
39 Chemical fruit thinning is faster than manual thinning, but it is climate-dependent, time-sensitive, and  
40 cultivar-dependent (Schupp et al., 2017; Tyagi et al., 2017). Mechanical blossom thinning has been  
41 shown to reduce fruit load, but it is non-selective, can increase the risk and transfer of disease, and can  
42 cause significant damage to spur leaf tissue (Kon & Schupp, 2018). Therefore, a more precise and  
43 selective solution is needed for the apple green fruit thinning. A robotic green fruit thinning system with  
44 selective fruit removal would potentially mitigate the drawbacks of existing methods.

45 The development of robotic systems for tree fruit production is primarily motivated by the challenges  
46 of decreasing labor availability and increasing associated costs. Typically, a robotic system includes a  
47 machine vision system for object detection, an end-effector for completing tasks, and a robotic  
48 manipulator and control system for positioning the end-effector to the target object. Previous studies  
49 have focused on the development of computer vision systems for agricultural applications, such as grape  
50 bunch detection (Pérez-Zavala et al., 2018), black rot detection in apples (Wang et al., 2017), and tomato  
51 maturity detection (Wan et al., 2018). Robotic harvesting is another focused area for numerous crops,  
52 such as apples (Silwal et al., 2017), oranges (Lee & Rosa, 2006), and tomatoes (Zhao et al., 2016).

53 Some research addressed robotic systems for crop thinning. For example, Lyons et al. (2015) developed  
54 and tested an automated selective thinning system for peach blossom removal. However, there are  
55 currently no known implementations of robotic technologies for the green fruit thinning of apples.

56 To design an effective green fruit thinning end-effector, it is important to understand green fruit  
57 removal dynamics. Several studies investigated removal dynamics for various fruits using pulling and  
58 twisting. Davidson et al. (2016) investigated handpicking dynamics for robotic apple harvester design.  
59 The results indicate that the detachment force required differs for each cultivar. The study also suggests  
60 using a tactile sensor in a robotic end-effector to determine the point of fruit separation and minimize  
61 the path traveled by the end-effector during harvesting. Li et al. (2016) indicated that a bending motion  
62 could improve the fruit detachment performance for apple picking. To remove fruit from the branch,  
63 bend-and-pull picking required less energy than pulling straight along the stem growth direction. Flood  
64 (2006) designed a robotic citrus harvesting end-effector and a force control model using physical  
65 properties and harvesting motion tests. Harvesting devices using cutting mechanisms have also been  
66 studied for various fruits. Van Henten et al. (2002) developed an autonomous robot for cucumber  
67 harvesting, which implemented an end-effector that grips and cuts the stems of cucumbers. Liu et al.  
68 (2011) developed a lychee harvester to cut off litchi bunches that utilized a cutting mechanism.  
69 However, green fruit thinning of apples is different from those harvesting operations. Green fruit  
70 thinning deals with fruit clusters by reducing the number of fruits growing in clusters. It is necessary to  
71 ensure no damage to the remaining fruits within the cluster while removing targets. Therefore, it is very  
72 important to investigate effective removal methods and corresponding fruit removal mechanisms.

73 The primary goal of this study was to investigate the dynamics for green fruit removal and to develop  
74 and evaluate a green fruit thinning end-effector prototype. The specific objectives are to 1) determine  
75 the force requirements for green fruit removal using pulling and stem-cutting methods, 2) design and  
76 develop a stem-cutting end-effector prototype, and 3) test the developed end-effector in an orchard  
77 environment by integrating the end-effector to two different base mechanisms, i.e., a handheld bar and

78 a robotic manipulator.

## 79 MATERIALS AND METHODS

### 80 2.1 EXPERIMENT SAMPLES

81 Two sets of tests including green fruit removal force measurement and end-effector performance  
82 were conducted at Penn State Fruit Research and Extension Center (FREC) in Biglerville, PA from late  
83 May to early June in 2021. Three apple cultivars were used in the tests, i.e., Fuji, GoldRush, and Golden  
84 Delicious. Fuji trees were planted in 2016, and trained to fruiting wall system by tying horizontal  
85 branches to trellis wires. GoldRush trees were planted in 2010, and trained to tall spindle structures  
86 with trellis support. Golden Delicious trees were planted in 2009 with the same training system as  
87 GoldRush trees. Table 1 shows the information for the test dates, type of tests, and numbers of fruit  
88 samples in each test. The fruits tested in the study were randomly selected from these trees, which were  
89 in clusters with three to five fruits.

90 **Table 1. Green fruit removal tests and fruit samples for these tests**

Tests	Test Dates	Cultivars	Sample numbers
Pulling Tests	5/19/2021	Fuji	60
	6/2/2021	GoldRush	50
	5/25/2021	Golden Delicious	40
Stem-Cutting Tests	5/28/2021	Fuji	100
	5/31/2021	GoldRush	100
	5/26/2021	Golden Delicious	100
End-effector test (Handheld)	5/28/2021	Fuji	50
	6/1/2021	GoldRush	50
	5/31/2021	Golden Delicious	50
End-effector test (Robotic arm)	6/3/2021	Golden Delicious	25

### 91 2.2 MEASURING OF GREEN FRUIT REMOVAL DYNAMICS

#### 92 2.2.1 *Fruit removal dynamics tests*

93 The force required to remove green fruit from a branch is a critical parameter for designing an  
94 effective robotic green fruit thinning end-effector. It is important to select a proper actuator that can  
95 provide sufficient force to remove targeted fruits. For this study, the dynamics for pulling and stem-  
96 cutting were assessed: (Figure 1). Experiments were conducted to test the two methods in May-June,  
97 2021, at the Fruit Research and Extension Center in Biglerville, PA. Three different apple cultivars were  
98 used for the experiments including 1) Fuji, 2) Golden Delicious, and 3) GoldRush.

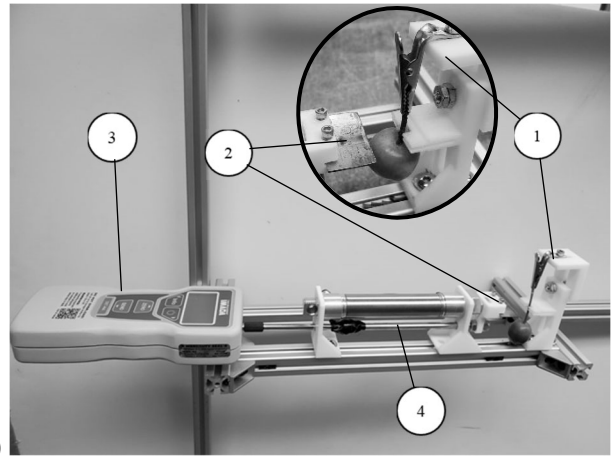

99

a)

b)

100 **Figure 1. Test setup for green fruit removal force measurement, a) pulling force measurement, b) stem-cutting force**  
 101 **measurement (1: stem-holding mount; 2) stem-cutting blade; 3) digital force gauge; 4) force-transfer rod)**

102 *2.2.1.1 Pulling*

103 This method is defined as the removal of green fruit by directly pulling them from tree branches. A  
 104 digital force gauge (DST-110A, Imada Inc., Northbrook, IL) pulled the fruit and recorded the required  
 105 forces. A piece of 2" PVC pipe was fastened to the end of the shaft of the digital force gauge with a  
 106 groove opened halfway into the PVC pipe to engage the fruit during pulling (Figure 1a). Pulling tests  
 107 were conducted in the orchards. Due to the flexibility of tree branches, anchoring fruit was necessary  
 108 during pulling. Two holding locations were tested: branch and fruit stem. Three apple cultivars were  
 109 tested, including 60 Fuji fruits (50 holding branch, 10 holding stem), 40 Golden Delicious fruits (30  
 110 holding branch, 10 holding stem), and 50 GoldRush fruits (40 holding branch, 10 holding stem). The  
 111 PVC pipe was placed around the fruit, with the stem placed inside the groove. The fruit was then  
 112 removed from the tree by pulling the digital force gauge with one hand and holding either the branch  
 113 or fruit stem with the other. For fruit removed while anchoring the branch, the stem detachment location  
 114 was noted, which can be either from the fruit-end or spur-end, as well as the peak pulling force. If the  
 115 fruit was detached with the stem (spur-end detachment), the pulling test was repeated while holding the  
 116 fruit stem to detach the fruit from the stem (fruit-end detachment), and the force was recorded again.  
 117 For each fruit, diameter was measured at the maximum circumference, stem length was measured from  
 118 spur-end to fruit-end, and stem diameter (only measured for GoldRush fruits) was measured at the  
 119 middle of a stem.

### 120 2.2.1.2 *Stem-Cutting*

121 This method is defined as removing a green fruit by cutting and breaking the fruit stem. To ensure  
122 consistent cutting behavior, a laboratory setup was built (Figure 1b). This setup included: 1) a custom  
123 3D-printed mount that hangs a fruit by its stem, with a groove in place to facilitate the cutting of the  
124 stem; 2) an unactuated pneumatic cylinder with a razor blade (Bi-metal utility blade, Irwin Tools,  
125 Huntersville, NC) attached to the end of its piston rod via a custom 3D-printed mount; 3) a digital force  
126 gauge (same as used in the pulling test); and 4) a long metal bolt, located underneath the pneumatic  
127 cylinder, with one end secured to the mount of the razor blade and the other secured to the digital force  
128 gauge. The long metal bolt was used to translate force between the mounted blade and the digital force  
129 gauge during testing. The entire setup was mounted on a t-slot extrusion rail. A green fruit was hung  
130 from the fruit mount by clipping its stem. The digital force gauge was then pushed very slowly to cut  
131 the fruit stem, such that the force applied could be considered approximately static. Finally, the peak  
132 force was recorded from the digital force gauge. The fruit diameter and stem length were measured for  
133 each fruit, and the stem diameter was measured for 50 GoldRush fruits.

### 134 2.2.2 *Data analysis for dynamic tests*

135 After the tests, the means and standard deviations of the fruit removal forces were obtained for each  
136 set of data in the experiments. A one-way ANOVA test was conducted to analyze the existence of  
137 significant differences among the fruit removal force means. A Games-Howell test, which does not  
138 assume equal variances for all data, was applied to determine which force means varied significantly  
139 from each other with a significance level of 5%. Linear regression models were applied to determine  
140 the relationships and goodness of fit between fruit/stem dimensions and required forces for removal.

## 141 2.3 STEM-CUTTING END-EFFECTOR DEVELOPMENT

### 142 2.3.1 *End-effector design*

143 As observed in the dynamics tests, despite lower force requirements for fruit removal, pulling green  
144 fruit without directly holding the stem may cause a large percentage of fruit to be removed at the spur-  
145 end, which can leave a wound area in a fruit cluster and affect the remaining fruits in the cluster (J. R.

146 Schupp, personal communication). Therefore, if implementing a pulling mechanism for an end-effector,  
147 it is necessary to have a secondary mechanism hold the stem while pulling fruit from trees to ensure no  
148 spur-end stem detachment. A stem-cutting mechanism could be a simpler solution, thus was used in this  
149 study. Figure 2 shows a design with a cutting mechanism that removes green fruit by cutting the stem.  
150 To minimize damage induced by the sharp cutting blade (component 2 in the Figure 2), the sharp edge  
151 was kept facing inside and the tip was rounded.

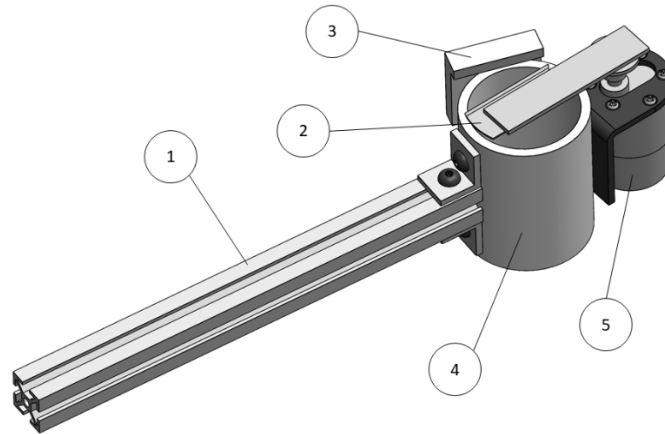

152  
153 **Figure 2. Stem-cutting end-effector prototype. Components: 1) handle; 2) blade; 3) 3D-printed cutting stopper; 4)**  
154 **PVC pipe; and 5) DC motor**

155 The end-effector prototype consists of a DC motor (JGB37-520, China Motor Factory, China) rated  
156 at 12V and 35 rpm, with a razor blade (same as was used in the dynamic test) attached to the end of its  
157 shaft. The motor was chosen based on the torque to provide sufficient cutting force for the cutting blade  
158 to remove fruit while being small enough to minimize the occurrence of collision with tree obstacles.  
159 With the multiplication of the distance between the motor shaft and the central cutting point (5 cm) and  
160 the maximum cutting force (45.7 N in Golden Delicious stem-cutting test), a DC motor with 25 kg·cm  
161 torque was selected. The motor was mounted onto a piece of 2-inch PVC pipe, which itself holds a  
162 custom 3D-printed mount used to assist in cutting stems. The PVC pipe was chosen such that it was  
163 large enough to encapsulate each target fruit. Two steps were used to remove fruits. The PVC pipe was  
164 placed to engage a fruit with its stem located at the entrance of the PVC pipe, and the DC motor was  
165 then actuated to rotate the razor blade along the entrance surface of the PVC pipe into the stem-cutting  
166 mount to break the fruit stem.



167 **2.3.2 End-effector control**

168 A system was designed to control the stem-cutting end-effector prototype (Figure 3). A  
169 microcontroller (Arduino Mega 2560, Arduino Inc., Italy) was the core component of the system. A  
170 motor shield (L298N, Qunqi, China) allowed the Arduino to control the DC motor using pulse-width  
171 modulation (PWM) signals with a frequency of 490 Hz. Specifically, the Arduino sent 5-volt PWM  
172 signals to the motor shield, which amplified the signal to 12-volt for the DC motor. Two tactile buttons  
173 (COM-10302, SparkFun Electronics, Niwot, CO) controlled the end-effector prototype: one for the  
174 forward razor motion, and the other for the backward razor motion. A potentiometer was used to  
175 manually set the duty cycle for the forward-motion PWM signal, and thus, set the speed of the forward  
176 razor motion.

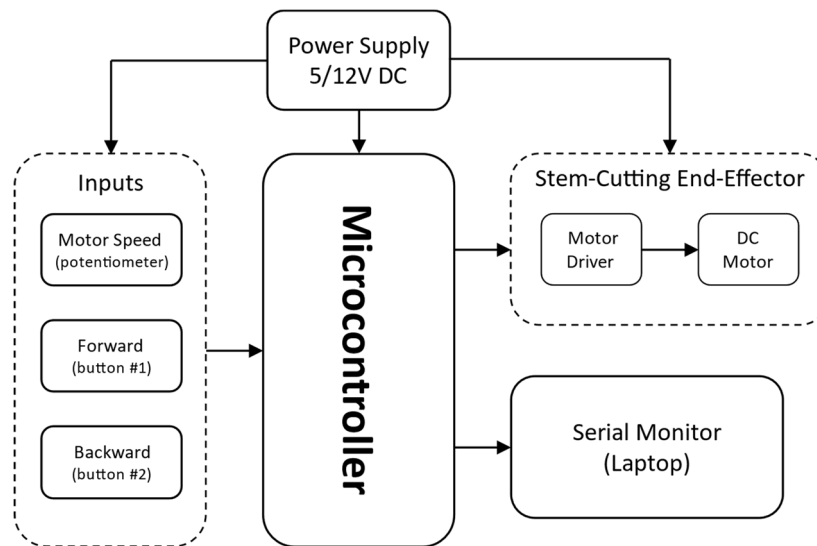

177  
178 **Figure 3. The controller flowchart of the developed stem-cutting end-effector**

179 The experimental stem-cutting steps for the end-effector prototype are illustrated in Figure 4. The  
180 steps include: 1) identify the targeted fruits to remove in a cluster. Typically, the king fruit in a cluster  
181 should be retained unless the fruit is abnormal, and the maximum final fruit set in a cluster is two or  
182 three (rare situation) depending on the crop density in a branch/tree. 2) Measure the targeted fruit  
183 diameter, as well as the stem length and stem diameter. 3) Position the end-effector prototype around  
184 the fruit such that the fruit is in place, and then actuate the end-effector motor to have the razor cut the  
185 stem. 4) Release the removed fruit by rotating the razor blade back to the initial position. Manual  
186 operations were made for identifying targeted fruits, encapsulating the fruit, and pressing the button to

187 rotate the motor and blade. In the future, these manual steps will be automated when an imaging system  
188 is employed.

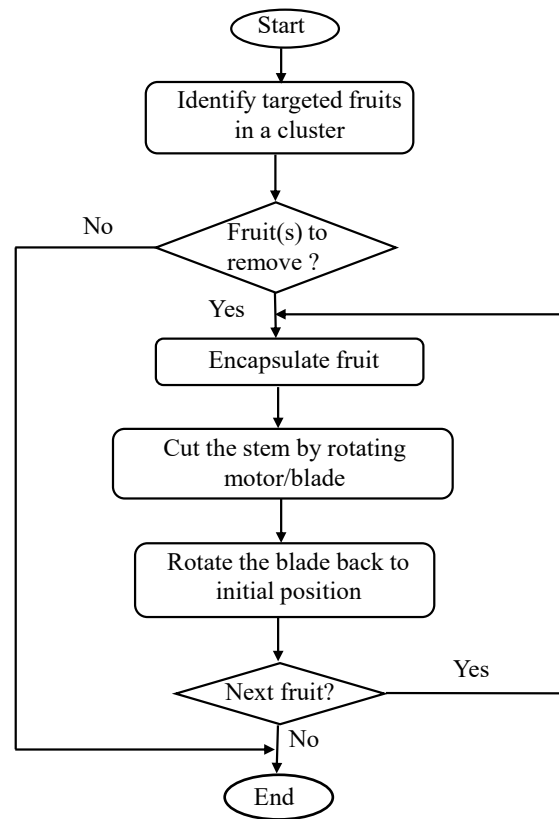

189  
190 **Figure 4. The process of identifying and removing fruit for end-effector**

#### 191 **2.4 END-EFFECTOR FIELD EVALUATION**

192 A series of green fruit thinning end-effector tests were conducted to evaluate the developed  
193 mechanism (testing dates and samples were described in section 2.1). Two settings were tested, one  
194 placing the end-effector onto a handheld bar, and the other integrating the end-effector with a six DoF  
195 robotic manipulator (UR5e, Universal Robots, Denmark) (Figure 5). The majority of tests were  
196 conducted with the handheld prototype, including 50 green fruit each for three cultivars, Fuji, Golden  
197 Delicious, and GoldRush. For the integrated robotic manipulator prototype, only 25 Golden Delicious  
198 green fruit were evaluated. These cultivars were selected in part due to their varying stem lengths, which  
199 is an important factor of fruit engagement by the end-effector. As the goal of thinning is to reduce the  
200 fruit count in a cluster, clusters of three to five fruits were randomly selected at different locations of  
201 the tree canopies. Both settings were tested with manual positioning of the end-effector around the

202 targeted fruits. A duty cycle of 100% was used for the forward-razor-motion PWM signal to ensure a  
203 maximum stem-cutting force. A duty cycle of 50% was used for the backward-razor-motion PWM  
204 signal to ensure a controlled return motion to reset the end-effector prototype for the next fruit. The  
205 manipulator was manually positioned to engage targeted fruits. The purpose of testing the end-effector  
206 with the robotic manipulator was to observe canopy-robot interaction during the green fruit thinning  
207 process, e.g., how well the end-effector can be maneuvered by the robotic manipulator through the  
208 canopy during thinning to provide guidance for further develop fully automated green fruit thinning  
209 system. The fruit length and diameter, as well as the stem length (and stem diameter for GoldRush  
210 fruits), were measured for the handheld and robotic manipulator implementations. The successfully  
211 removed fruit were recorded and used to calculate the green fruit removal success rate. The limitations  
212 or reasons for removal failures were also noted.



213  
214 **Figure 5. Field tests of the green fruit thinning end-effector, left) handheld type, and right) attached to a six DoF**  
215 **robotic manipulator**

## 216 **RESULTS AND DISCUSSION**

### 217 **3.1 PARAMETERS OF REMOVED FRUITS**

218 The mean fruit diameters for each cultivar were similar for the stem-cutting tests (Table 2). The fruit  
219 diameter for each cultivar varied for the pulling tests. This is due to the larger time frame in which the  
220 pulling tests took place compared to the stem-cutting tests. The mean stem lengths for the Fuji and

221 GoldRush cultivars did not differ greatly from each other, for both the pulling and stem-cutting tests.  
 222 However, for both tests, the mean Golden Delicious stem length was significantly greater than both Fuji  
 223 and GoldRush. The mean stem diameter for GoldRush did not vary greatly between the pulling and  
 224 stem-cutting tests. Fruit diameter and stem length means did not vary greatly among handheld end-  
 225 effector tests and fruit removal dynamics tests for each cultivar, except the fruit diameter mean for the  
 226 Fuji cultivar during pulling tests, which was notably less. The mean fruit diameter for Golden Delicious  
 227 for the robotic arm housed end-effector tests was considerably greater than that for the handheld end-  
 228 effector tests, whereas the mean stem length for Golden Delicious for the robotic arm end-effector tests  
 229 was considerably less than that for the handheld end-effector tests. The decrease in measured stem  
 230 length for the same cultivar between tests is likely due to the shoulders of fruit starting to encapsulate  
 231 part of the stem when they grow larger.

232 **Table 2. Basic parameters of the fruits tested in the dynamic tests and end-effector tests**

Tests	Cultivars	Fruit Dimensional Parameters (mm)		
		Fruit diameter	Stem length	Stem diameter
Pulling Tests	Fuji	16.1±3.6	26.2±3.9	-
	GoldRush	24.5±1.8	24.1±3.7	1.89±0.21
	Golden Delicious	19.8±2.5	44.7±5.5	-
Stem-Cutting Tests	Fuji	22.5±3.2	25.8±4.2	-
	GoldRush	22.7±2.1	21.6±3.6	1.99±0.21
	Golden Delicious	20.7±1.8	40.7±5.8	-
End-effector test (Handheld)	Fuji	21.0±3.9	27.7±5.7	-
	GoldRush	21.8±3.1	24.8±3.4	-
	Golden Delicious	22.8±3.1	39.2±5.0	-
End-effector test (Robotic arm)	Golden Delicious	27.5±2.5	34.7±4.6	1.87±0.22

### 233 3.2 GREEN FRUIT REMOVAL DYNAMICS RESULTS

234 Table 3 shows the means and standard deviations for the pulling and stem cutting forces required for  
 235 fruit removal for three cultivars. The pulling test detachment success percentages are also listed based  
 236 on detaching location. The overall mean required removal force values among all three cultivars for  
 237 each removal method are also provided.

238 **Table 3. Means and standard deviations for the fruit-removal dynamics experiments. Each mean belonging to a single**  
 239 **letter group is not significantly different from others within the group.**

Cultivars	Stem Cutting Force (N)	Spur-End Pulling Force (N)	Fruit-End Pulling Force (N)	Pulling Detached Location (%)	
				Fruit-end	Spur-end
Fuji	36.3±5.8 <sup>a</sup>	20.5±5.1 <sup>d,e</sup>	26.6±5.4 <sup>b,c</sup>	28%	72%
Golden Delicious	37.1±8.6 <sup>a</sup>	19.5±4.2 <sup>d,e</sup>	23.7±6.7 <sup>c,d</sup>	50%	50%
GoldRush	27.5±5.2 <sup>b</sup>	19.1±3.5 <sup>e</sup>	23.5±5.2 <sup>c,d</sup>	60%	40%

Overall	33.6±8.0	19.9±0.6	24.8±0.5	42%	58%
---------	----------	----------	----------	-----	-----

240

241 No significant differences were found among cultivars for either spur-end detachment force or fruit-  
 242 end detachment force. However, detachment forces were significantly smaller for spur-end detachment  
 243 compared to fruit-end detachment forces for each cultivar. When pulling fruit from the clusters by  
 244 holding the branch, a large portion of fruit were detached from the spur-end. The spur-end detachment  
 245 rate for the Fuji cultivar was particularly high at 72%. Thus, to ensure fruit-end detachment if using a  
 246 pulling end-effector, a secondary mechanism should be used to hold the stem during the pulling  
 247 operation. In the pulling test, for fruits first detached from the fruit-end, there was no way to measure  
 248 the spur-end detachment force, while for fruits first detached from the spur-end, the fruit-end  
 249 detachment force was also measured by manually holding the stem. For some cultivars (particularly  
 250 GoldRush), the fruit-end detachment rate is slightly higher than that of spur-end detachment even  
 251 though the mean force for fruit-end detachment was greater. The absence of some spur-end detachment  
 252 force measurements may partially explain the big difference in the mean forces.

253 For the stem-cutting test, no significant difference was found for mean cutting forces between the  
 254 Fuji and Golden Delicious cultivars. However, Fuji and Golden Delicious mean cutting forces were  
 255 found to be significantly greater than that of GoldRush. Overall, the mean stem cutting forces for all  
 256 fruits were found to be significantly greater than corresponding mean pulling forces. Although based  
 257 on these results, a stem-cutting end-effector would require more force than a pulling end-effector, it is  
 258 relatively easier to design since it does not require a secondary mechanism to secure the stem during  
 259 the fruit removal. Therefore, a stem-cutting mechanism was developed based on the stem cutting force  
 260 measurement for the end-effector field evaluation test.

261 As indicated earlier, fruit diameter and stem length/diameter were measured. The relationships  
 262 between fruit parameters were plotted with the force required for fruit removal (Figures 6-8). Linear  
 263 regression models were then applied to indicate these relationships, with goodness-of-fit ( $R^2$ ) provided.

264 As the figures show, there were no significant correlations between any fruit parameters and fruit-  
 265 removal force for either removal method in the three cultivars. In each individual test, the fruit diameter  
 266 differences were typically within 10 mm, which showed a certain uniformity of fruit size at a time. Due  
 267 to limited time, not all tests were conducted on the same day when the fruit were at similar diameters.  
 268 For example, the stem-cutting tests for the Fuji cultivar occurred later than the pulling tests for the  
 269 cultivar. The stem-cutting mean forces were found to be significantly greater than both pulling mean  
 270 forces for the Fuji cultivar. However, stem-cutting forces were also significantly greater than the pulling  
 271 forces for the other two cultivars, which had similar fruit diameter ranges across all three removal tests.  
 272 Therefore, the delay in stem-cutting fruit removal for the Fuji cultivar does not necessarily explain the  
 273 increase in required stem cutting force. Further studies are planned to investigate the relationship  
 274 between the removal force and the time of removal after petal fall.

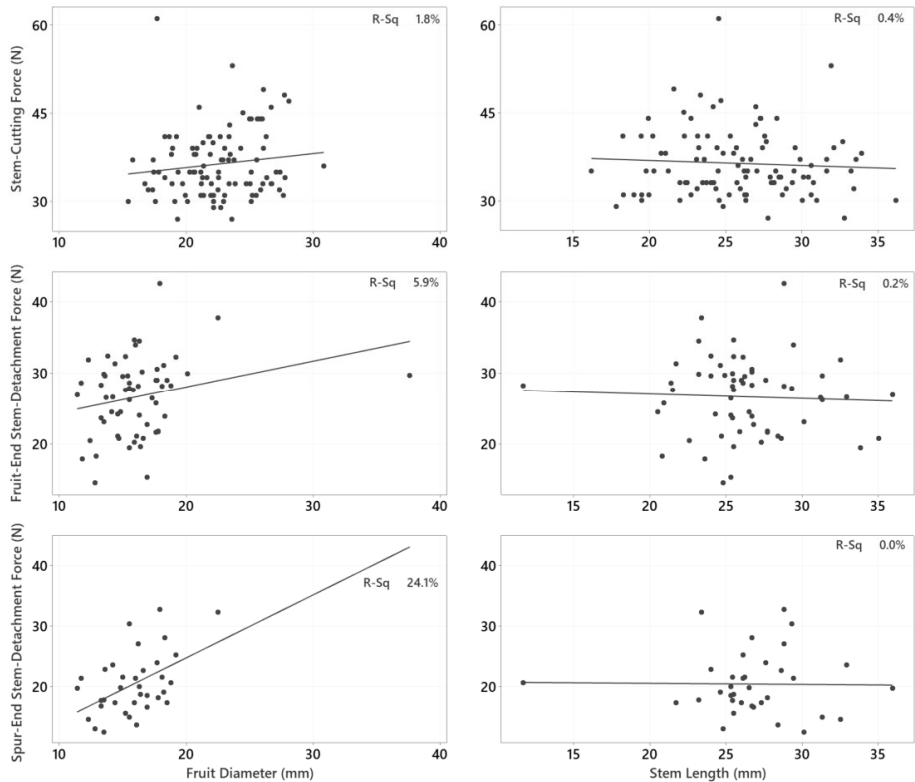

275  
 276 **Figure 6. Scatterplots for Fuji fruits on the relationship between fruit parameters and fruit removal forces**

277

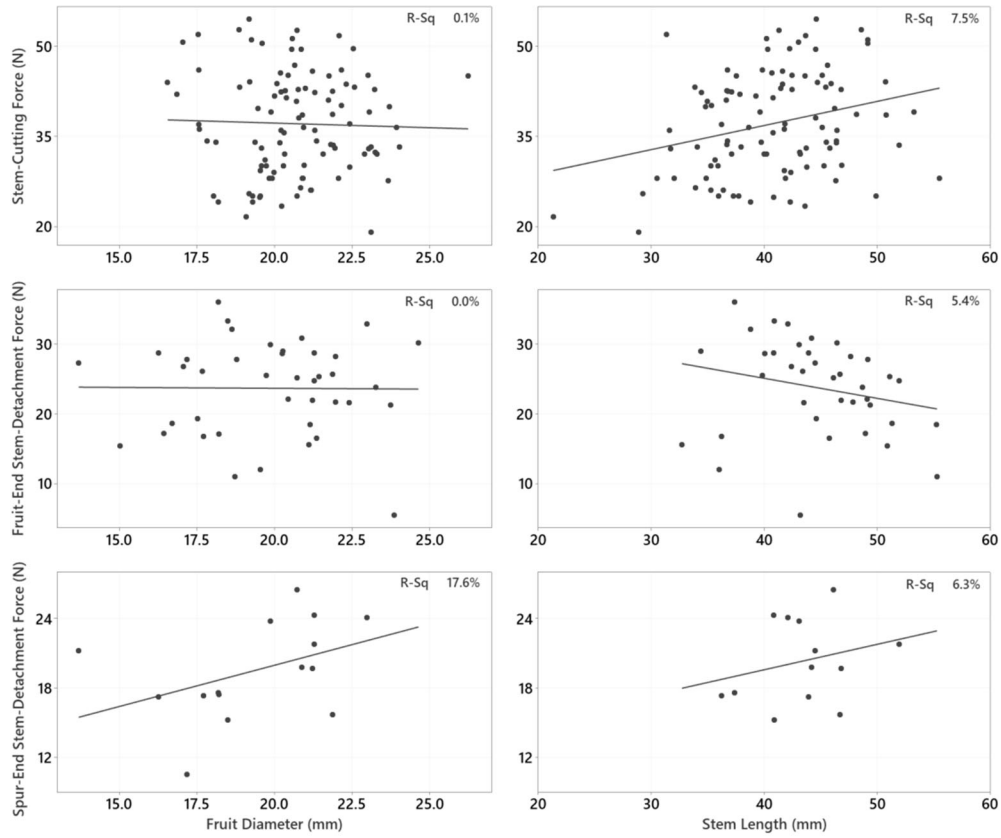

278  
279

Figure 7. Scatterplots for Golden Delicious fruits on the relationship between fruit parameters and fruit removal forces

280

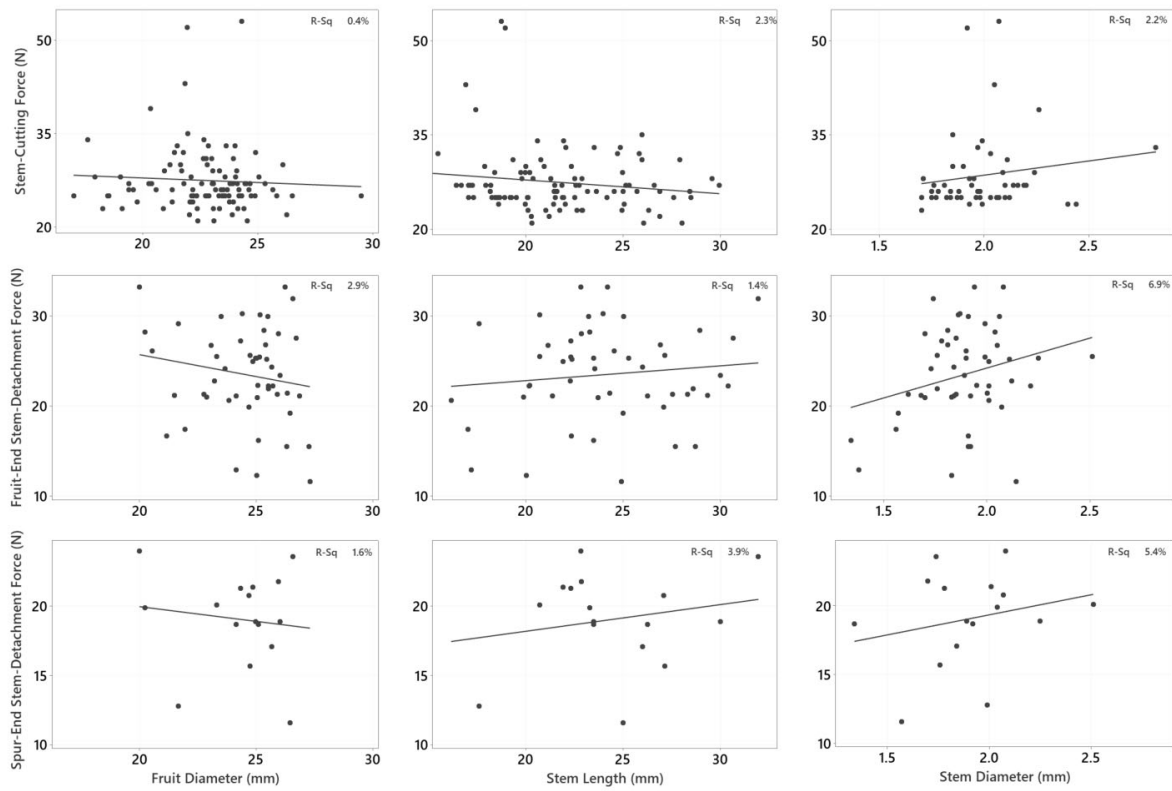

281

Figure 8. Scatterplots for GoldRush fruits on the relationship between fruit parameters and fruit removal forces

282 The differences among the stem lengths can be more than 20 mm even in the same test cultivar, while  
 283 no strong correlation has been found between the stem length and required force for all tests. Golden  
 284 Delicious apples have much longer stems than the other two. Typically, when the stem is longer, there  
 285 is more open space around the fruit, which serves as an advantage when implementing robotic green  
 286 fruit thinning by allowing for easier navigation. For the GoldRush cultivar, the required fruit removal  
 287 forces were found to slightly increase along with stem diameter, although this relationship was found  
 288 to be very weak. One reason could be that these stem diameters among the fruits were very similar at a  
 289 given time, mostly in the  $2\pm 0.5$  mm range. The stem diameter was not recorded for Fuji and Golden  
 290 Delicious fruits, although similar situations would likely occur for these fruits as well.

### 291 3.3 STEM-CUTTING END-EFFECTOR PROTOTYPE RESULTS

292 The results for the stem-cutting end-effector prototype experiments are shown in table 4. Among all  
 293 the tests, including using the handheld prototype and robotic arm, high success rates of over 90% were  
 294 achieved with single cut trial for all cultivars. In most cases, the end-effector could engage fruit without  
 295 interference from obstacles, while for some fruits, leaves or shoots may need to be pushed aside. The  
 296 GoldRush cultivar had a relatively lower success rate compared to the other two cultivars, which is  
 297 possibly due to the shorter stem for these apples. The chances of cutting leaves or spurs were higher if  
 298 the fruit stem was shorter. For densely-packed clusters, the targeted fruit could only be engaged within  
 299 the PVC pipe either when other fruit in the cluster were pushed away, or the end-effector was offset.  
 300 The major reason for the failures was due to obstacles such as leaves or spurs being stuck in the cutting  
 301 pathway. A more powerful cutting mechanism may help improve the success rate, although it is not  
 302 ideal to damage leaves or spurs during green fruit removal. Therefore, more effort should be put into  
 303 the improvement of the mechanism to possibly move these leaves or shoots aside when engaging with  
 304 the target fruits.

305 **Table 4. The performance of the developed stem-cutting end-effector in the field tests**

Tests	Cultivars	Total No. Fruits	Removed Fruits	Success Rate
Handheld prototype	Fuji	50	47	94%



	Golden Delicious	50	48	96%
	GoldRush	50	45	90%
Robotic arm prototype	Golden Delicious	25	23	96%

306

307 Overall, the stem cutting mechanism effectively cut and removed the majority of the targeted green  
308 fruit. In particular, the test with the six DoF robotic arm achieved a very high success rate, which  
309 provides potential for further development of a full robotic green fruit thinning system. The manipulator  
310 could be maneuvered around the canopy without considerable difficulty when reaching target fruit.  
311 However, for fruits located near the edge of the manipulator’s workspace, only fruit facing directly  
312 towards the base of the manipulator could be properly encapsulated by the end-effector, due to it being  
313 mounted collinearly to the tool end of the manipulator. At this point, all the fruit engagements were  
314 accomplished manually. With the future development of systems for machine vision and control, the  
315 stem-cutting end-effector could be integrated as a core component of the robotic system. For dense  
316 clusters, the end-effector would need to be offset so as to not collide with other fruits. The reachability  
317 of the manipulator also needs to be considered when implementing the end-effector on a robotic  
318 manipulator to optimize fruit-removal effectiveness at the edge of the manipulator’s workspace.

319 The tests showed that when designing an effective stem-cutting robotic end-effector system for green-  
320 fruit removal, there are several criteria to be considered. First, the system needs to be able to detect the  
321 location of a fruit’s stem with high precision. Second, the size of the end-effector needs to be compact  
322 enough to allow for optimal maneuverability. Third, the end-effector relative to the robotic manipulator  
323 needs to be oriented for optimal fruit removal without the manipulator unintentionally colliding with  
324 the tree. The size of the end-effector prototype was also shown to be a limitation in effective fruit  
325 removal. The PVC-pipe enclosure was considerably larger than all the fruit, ~50 mm, and the largest  
326 fruit was not greater than 30 mm. While a larger enclosure allows for a larger margin of error for a  
327 robotic system engaging green fruits, a smaller one could be used to allow for better maneuverability  
328 of the end-effector. Furthermore, for a path-planning algorithm, stricter boundaries would need to be

329 imposed to prevent collision of the tree canopy and end-effector. The DC motor-based prototype also  
330 limited the maneuverability of the end-effector, as its location near the cutting mechanism made it  
331 harder to target certain fruit when other obstacles such as leaves and other fruits were nearby. Once the  
332 intended fruit was encapsulated in the end-effector, the orientation of the end-effector relative to the  
333 stem was not found to significantly affect the performance of the end-effector in fruit removal. The end-  
334 effector was able to cut the stem successfully even at large angles between the fruit and end-effector.

335 As shown in the field test, the implementation of the stem-cutting end-effector prototype onto a  
336 robotic manipulator was proven to be overall effective in reaching and removing targeted fruits. In the  
337 future, with the implementation of the improvements for the end-effector previously mentioned, success  
338 in removing green fruit could be potentially increased. While a pulling-based end-effector is not  
339 investigated in this study due to design complexity, such a design may be considered in the future.  
340 Although the end-effector performed well in green fruit removal when applied manually, to obtain a  
341 completely autonomous green fruit thinning system, a machine vision system will need to be  
342 implemented that helps determine fruit and obstacle locations, as well as a collision-free path planning  
343 algorithm. Currently, a study on green fruit and stem instance segmentation and orientation estimation  
344 is ongoing using color images. It is intended that the fruit locations and orientations calculated from the  
345 study can guide the developed green fruit thinning end-effector to remove the targeted fruits precisely  
346 and successfully, along with collision-free paths to achieve robotic green fruit thinning for full  
347 automation.

## 348 **CONCLUSIONS**

349 A series of green fruit removal dynamic tests were conducted to identify the detachment force  
350 required for robotic green fruit thinning. A stem-cutting end-effector was then developed and tested in  
351 the field using two methods of manipulation. The following conclusions were drawn from the study.

352 1. The pulling method required less force than the stem cutting method to remove fruit using the  
353 designed devices in the fruit removal experiments. However, the high rate of spur-end detachment

354 when holding the branch would be a concern for practical operations.

355 2. The force requirements for fruit removal did not vary significantly between the tested cultivars in  
356 most cases, the only exception was that GoldRush required significantly less force for stem cutting  
357 compared to the other two cultivars. Also, since no significant relationship was found between the  
358 force requirements and the measured fruit/stem dimensions, the fruit parameters may not serve as  
359 variables in determining the required force for detaching the fruit.

360 3. The stem-cutting end-effector showed the capability to remove green fruit and could serve as  
361 foundation for further research on end-effector development for robotic green fruit thinning. Its  
362 integration with a robotic manipulator worked well as a mechanical system for green fruit removal.

363 In summary, as a core component, the stem-cutting end-effector showed great potential as a  
364 component of a robotic green fruit thinning system. In the future, integrating the end-effector with a  
365 machine vision system to identify the fruit locations, determine the target fruit, and navigate the robotic  
366 system to engage the fruits will be the major steps to develop a robotic green fruit thinning system.

### 367 **ACKNOWLEDGMENTS**

368 This research was partially supported in part by the United States Department of Agriculture  
369 (USDA)'s National Institute of Food and Agriculture (NIFA) Federal Appropriations under Project  
370 PEN04653 and Accession No. 1016510. We would like to give our special thanks for the support from  
371 the USDA NIFA AFRI Foundational and Applied Science Program Grant 2020-67021-31959 and the  
372 USDA NIFA Specialty Crop Research Initiative Grant 2020-51181-32197. The authors also would like  
373 to thank Tyler Shannon (an undergraduate research assistant) for assisting with field data collection.

### 374 **REFERENCES**

375 Davidson, J., Silwal, A., Karkee, M., Mo, C., & Zhang, Q. (2016). Hand-picking dynamic analysis for  
376 undersensed robotic apple harvesting. *Transactions of the ASABE*, 59(4), 745–758.  
377 Einhorn, T. C., & Arrington, M. (2018). ABA and shading induce 'Bartlett'pear abscission and inhibit  
378 photosynthesis but are not additive. *Journal of Plant Growth Regulation*, 37(1), 300–308.

379 Fernández, F. J., Ladux, J. L., & Searles, P. S. (2015). Dynamics of shoot and fruit growth following fruit thinning  
380 in olive trees: same season and subsequent season responses. *Scientia Horticulturae*, *192*, 320–330.

381 Flood, S. J. (2006). *Design of a robotic citrus harvesting end effector and force control model using physical*  
382 *properties and harvesting motion tests*. *73*(5).

383 Giovanaz, M. A., Amaral, P. A., Pasa, M. da S., de Lima, A. P. F., Weber, D., & Fachinello, J. C. (2016). Chemical  
384 Thinning Affects Yield and Return Flowering in “Jubileu” Peach. *Revista Ceres*, *63*(3), 329–333.  
385 <https://doi.org/10.1590/0034-737X201663030008>

386 Kon, T. M., & Schupp, J. R. (2018). Apple crop load management with special focus on early thinning strategies:  
387 A US perspective. *Horticultural Reviews*, *Volume 46*, *46*, 255–298.  
388 <https://doi.org/10.1002/9781119521082.ch6>

389 Lee, B. S., & Rosa, U. A. (2006). *Development of a Canopy Volume Reduction Technique for Easy Assessment*  
390 *and Harvesting of Valencia Citrus Fruits*. *49*(1982), 1695–1704.

391 Li, J., Karkee, M., Zhang, Q., Xiao, K., & Feng, T. (2016). Characterizing apple picking patterns for robotic  
392 harvesting. *Computers and Electronics in Agriculture*, *127*, 633–640.

393 Liu, T. H., Zeng, X. R., & Ke, Z. H. (2011). Design and prototyping a harvester for litchi picking. *Proceedings -*  
394 *4th International Conference on Intelligent Computation Technology and Automation, ICICTA 2011*, *2*, 39–  
395 42. <https://doi.org/10.1109/ICICTA.2011.302>

396 Looney, N. E. (2018). *Growth regulator usage in apple and pear production*. In *Plant growth regulating*  
397 *chemicals*. CRC Press.

398 Lyons, D. J., Heinemann, P. H., Schupp, J. R., & Baugher, T. A. (2015). Development of a Selective Automated  
399 Blossom Thinning System for Peaches. *Transactions of the ASABE (American Society of Agricultural and*  
400 *Biological Engineers)*, *58*(6), 1447–1457.  
401 [https://www.researchgate.net/publication/290654648\\_Development\\_of\\_a\\_selective\\_automated\\_blossom\\_](https://www.researchgate.net/publication/290654648_Development_of_a_selective_automated_blossom_thinning_system_for_peaches)  
402 [thinning\\_system\\_for\\_peaches](https://www.researchgate.net/publication/290654648_Development_of_a_selective_automated_blossom_thinning_system_for_peaches)

403 Pérez-Zavala, R., Torres-Torriti, M., Cheein, F. A., & Troni, G. (2018). A pattern recognition strategy for visual  
404 grape bunch detection in vineyards. *Computers and Electronics in Agriculture*, *151*(September 2017), 136–  
405 149. <https://doi.org/10.1016/j.compag.2018.05.019>

406 Schupp, J. R., Winzeler, H. E., Kon, T. M., Marini, R. P., Baugher, T. A., Kime, L. F. ., & Schupp, M. A. (2017).

407 A Method for Quantifying Whole-tree Pruning Severity in Mature Tall Spindle Apple Plantings.  
408 *HortScience*, 52(9), 1233–1240.

409 Silwal, A., Davidson, J. R., Karkee, M., Mo, C., Zhang, Q., & Lewis, K. (2017). Design, integration, and field  
410 evaluation of a robotic apple harvester. *Journal of Field Robotics*, 34(6), 1140–1159.  
411 <https://doi.org/10.1002/rob.21715>

412 Tyagi, S., Sahay, S., Imran, M., Rashmi, K., & Mahesh, S. S. (2017). Pre-harvest Factors Influencing the  
413 Postharvest Quality of Fruits: A Review. *Current Journal of Applied Science and Technology*, 23(4), 1–12.

414 USDA-NASS. (2020). National Statistics for Apples. *Washington, DC: USDA-NASS*.

415 Van Henten, E. J., Hemming, J., Van Tuijl, B. A. J., Kornet, J. G., Meuleman, J., Bontsema, J., & Van Os, E. A.  
416 (2002). An Autonomous Robot for Harvesting Cucumbers in Greenhouses. *This Paper Describes the*  
417 *Concept of an Autonomous Robot for Harvesting Cucumbers in Greenhouses. A Description Is given of the*  
418 *Working Environment of the Robot and the Logistics of Harvesting. It Is Stated That for a 2 Ha Dutch*  
419 *Nursery, 4 Harvesting Robot*, 13(3), 241–258. <https://doi.org/10.1023/A>

420 Vanheems, B. (2015). *How to Thin Fruit for a Better Harvest*. *GrowVeg*. [https://www.growveg.com/guides/how-](https://www.growveg.com/guides/how-to-thin-fruit-for-a-better-harvest/)  
421 [to-thin-fruit-for-a-better-harvest/](https://www.growveg.com/guides/how-to-thin-fruit-for-a-better-harvest/)

422 Wan, P., Toudeshki, A., Tan, H., & Ehsani, R. (2018). A methodology for fresh tomato maturity detection using  
423 computer vision. *Computers and Electronics in Agriculture*, 146(February 2017), 43–50.  
424 <https://doi.org/10.1016/j.compag.2018.01.011>

425 Wang, G., Sun, Y., & Wang, J. (2017). Automatic Image-Based Plant Disease Severity Estimation Using Deep  
426 Learning. *Computational Intelligence and Neuroscience*, 2017. <https://doi.org/10.1155/2017/2917536>

427 Zhao, Y., Gong, L., Liu, C., & Huang, Y. (2016). Dual-arm Robot Design and Testing for Harvesting Tomato in  
428 Greenhouse. *IFAC-PapersOnLine*, 49(16), 161–165. <https://doi.org/10.1016/j.ifacol.2016.10.030>