

# Improved Precision Sow Feeder with Mass-Based Measurement System

## Contestants

Grayson Averette, Lily Averette, Joseph Hanks, Justin Raver

## School & Department

North Carolina State University  
Department of Biological and Agricultural Engineering

## Advisors

Dr. Suzanne Leonard, Dr. Michael Boyette, Dr. Andy Hale, Dr. Grant Ellington







## Date of Graduation

6 May 2023

## Department Head

Dr. Garey Fox

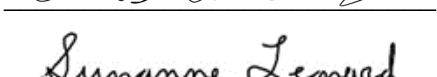
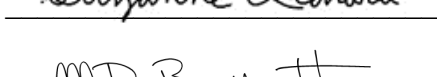
## Signatures

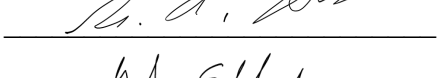
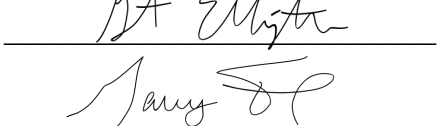
Grayson Averette:		Date: 5/05/2023
Lily Averette:		Date: 4/28/2023
Joseph Hanks:		Date: 4/28/2023
Justin Raver:		Date: 4/28/2023
Dr. Suzanne Leonard:		Date: 4/28/2023
Dr. Michael Boyette:		Date: 4/28/2023
Dr. Andy Hale:		Date: 5/05/2023
Dr. Grant Ellington:		Date: 4/28/2023
Dr. Garey Fox:		Date: 4/28/2023

# Precision Sow Feeder

## Abstract

Auger mounted dropbox feeders are widely used in gestation barns to feed both stall and pen housed sows. These dropbox feeders have a range of 1.5-12 lb and are relatively inexpensive. However, they are not consistent in their precision because they measure feed on a volume basis and fail to account for the several factors affecting feed density. Feeder inaccuracies can either drive feed costs upward due to waste or create costly health problems for gestating sows due to underfeeding. There are electronic feeders with high precision available, but these are much more expensive, not retrofittable, and require continuous, highly-skilled maintenance. The purpose of designing this improved feeder was to create an inexpensive retrofittable product with increased precision compared to existing volume-based feeders. The designed feeder employs a nested dropbox system with the inner dropbox suspended from extension springs to measure feed on a mass basis instead of the traditional volume basis. As the feeder fills, its extension springs displace until the desired amount is reached and instantaneous shutoff of the feed flow occurs via a modular trigger system. When compared to the error in feed drop weight of a volume based feeder, the designed feeder on average had 0.3 lb less error with each drop, potentially saving as much as \$400 per day per 1000 sows in feed costs. The prototyped feeder provides a plausible solution to feeder inaccuracies that could be manufactured with blow formed plastic at a lower cost than electronic feeders on the market.

## Acknowledgements

Special thanks is given by the team to Dr. Suzanne Leonard who has been a source of constant support as the team faculty sponsor and has provided essential feedback throughout the project timeline. The team would also like to express gratitude to the advisory board members for the precision feeder project; Mr. Jacob Dunn, Mrs. Alysondria Eason, and Dr. Bryan Staley for their support and invaluable assessments of the project deliverables and intermittent presentations. The assistance and guidance of Dr. Mike Boyette, Dr. Grant Ellington, and Dr. Andy Hale has been vital to the success of the project at each step of the project timeline. The assistance by the research shop staff Neil Bain and Joseph Blalock, as well as Jay Campbell is greatly appreciated. Finally, the team would like to thank the NCSU Biological and Agricultural Engineering department and Dr. Suzanne Leonard for providing the financial contributions necessary for our team to reap the benefits and invaluable experience of completing this engineering project.

## Table of Contents

Abstract.....	2
Acknowledgements.....	2
Table of Contents.....	3
I. Introduction.....	4
II. Design Goals and Objectives.....	5
III. Engineering Design Process.....	6
a. Initial Steps.....	6
b. Prototype Design.....	7
c. Adjustment and Feed Shutoff Design.....	8
d. Feed Release Design.....	9
e. Auger Connection Design.....	9
f. Electrical Components.....	9
g. Similarities to Existing Feeders.....	10
h. Materials.....	10
i. Calibration.....	11
IV. Budget and Bill of Materials.....	11
V. Design Testing and Future Considerations.....	12
a. Analysis of Precision and Accuracy of Feeder.....	12
b. Future Considerations.....	14
VI. Conclusions.....	15
VII. References.....	16
VIII. Appendix A: Drawings.....	17
IX. Appendix B: Bill of Materials.....	21
X. Appendix C: Arduino Code.....	22

## I. Introduction

Current feeders and feeding practices used in the swine industry have substantial variability, which is especially problematic for gestating sows, who must be fed the proper amount of feed to limit over conditioning and under conditioning (Gaillard and Dourmad, 2022). Too much feed can lead to birth complications and too little feed can result in lactation insufficiencies. Sows are often fed 4 to 7 lb of feed per meal, with 6 lb of feed being the average. Current inadequacies associated with volume-based feeders can cause the weight of dispensed feed to vary by  $\pm 1$  lb, creating a considerable error.

Cost efficiency is a major aspect to consider in the swine industry, with feed costs accounting for approximately 70% of total expenses in swine production. Therefore, wasted feed can be one of the most impactful financial burdens for farms. By increasing the feeder precision, profit margins can be improved and feed costs can be minimized. While the wasted feed can be economically unsustainable, it also can have environmental effects in regard to sustainability. More precision in the feeding system will allow transportation costs and routes to be optimized by reducing the amount of trips feed trucks must take to the farm. Additionally, higher precision of sow feed intake will improve downstream conditions in regard to manure management (Carlson, 2018) and simplify environmental concerns such as soil nutrient management.

Sows are usually housed in either group pens or individually in stalls. In stall housing there is greater allowance for individual care and more attention can be given to how much a particular sow is being fed. This attention is particularly useful during gestation. With that being said, as of 2018, nine states enacted bans on stall housing due to the limited space allowance and concerns with social behavior (Thomas et al., 2018). Due to these legislative changes, group housing in pens has become more popular throughout the swine industry. However, with group housing there is also more competition for food, which creates issues when trying to ensure each sow is getting the correct amount of feed. There has been research catered to feeder designs that address this issue, much of which focuses on electronic feeders.

There are two basic types of feeders currently on the market which were used as a baseline throughout the design process. One is a hand feeder (figure 1), that requires the feed to be manually scooped in each individual feeder, making it time consuming to employ. This type of feeder often consists of a hard plastic hopper at the top connected to a metal casing that contains a lever for adjusting the amount of feed the sow is able to receive. The second kind of feeder is a dropbox (figure 2), which is attached to an auger that runs along the ceiling. This feeder has a manually adjusted pull tab that controls the volume of feed dispensed into the box by the auger. This feeder style is



*Figure 1: Hand feeder with hopper and metal casing*



*Figure 2: Adjustable feeder attached to auger*

primarily constructed of hard plastic. Additionally, in a lot of gestation barns, a pull-cord system is used alongside these adjustable feeders attached to augers. With this system, a cord runs along the ceiling beneath the auger and is attached to ball weights in the outflow openings of each dropbox. When this cord is pulled, it pulls the ball weight to release feed into the feed tube and trough. The problem with this system is that only one row of feed is dropped at a time, which can cause irritability amongst the sows that are on the latter rows. Both of these feeders lack precision and can be difficult to adjust.

Overall, there is a need for design improvements to feeders that are most commonly used on farms today. This is due to the current lack of precision and repeatability in feed distribution. Additionally, while there are more precise electronic feeders available, these feeders are costly and are not retrofittable to current feeding systems. Clogging is also an issue in some current feeders that has negative impacts on the amount of feed the sow may receive. All of these factors contribute to the need for design improvements in current feeders on the market.

## **II. Design Goals and Objectives**

The major goal of this project was to design and create a precision sow feeder prototype that was easily retrofittable to current feed line and hand feeding systems in gestation barns. Additionally, the design needed to remain user friendly with limited technical skill or training requirements. The prototype was designed to resolve several issues with current sow feeders, and ultimately aimed to improve the efficiency of swine production.

The precision feeder design needed to implement an adjustable mechanism for variances in 4 to 7 lb of feed, and an element for 0.25-lb increments. Additionally, feed clogging was to be mitigated. Selection of construction materials needed to maintain the robustness of the feeder so it could endure the harsh conditions of a swine barn. Ability for the device to be integrated into the existing feed delivery system of each barn also had to be considered as different barns have different auger sizing, flow rates, and feed delivery methods. Simultaneous feed delivery was another main objective for this project to alleviate competition among sows in the barn, especially for those in group housing. Lastly, to ensure that the final product would be marketable, the design had to keep the cost of the final feeder and components to approximately \$25 per unit. This cost was based on the average market price for current feeders.

During the design process, it was important to analyze which aspects of the project were crucial in achieving the goals. Various tradeoffs needed to be examined in an effort to create a product with the optimal number of benefits. This specifically came into play in regard to economics. Being that during the course of the project, pricing of materials increased, there was a natural progression of creating a product that, too, had an increase in pricing. Further, specific electrical components were deemed necessary to achieve the main goals of the project. This was an evident tradeoff that was necessary in order to fulfill some of the more pressing needs of the project. It was also important to acknowledge that the cost to fabricate a prototype is always more than the product cost if the product were to be mass produced. These tradeoffs will be further discussed as the solution that was decided upon is explained.

### III. Engineering Design Process

#### a. Initial Steps

To meet the objectives and design criteria, the first step was to determine design constraints from existing feed delivery systems and the type of feed used. To start, data was gathered on the characteristics and dimensions of existing feed augers and hand feeding systems from manufacturers such as Hog Slat, Inc. and Chore Time. Additionally, in order to gain a better understanding of the feeding systems as a whole and to witness first-hand the environments these feeders are in, a visit to NC State's Swine Education Unit (SEU) was planned. Dimensions were collected at the SEU as well. The dimensions obtained were then used to determine how the precision feeder could be designed to fit the widest range of existing feed systems possible.

Consideration was also given to the flex auger providing the feed at the top of the dropbox and the tubing beneath the dropbox where the feed is released. The next step was to investigate the different types of feed used for gestating sows and find the most common combinations of feed used. The moisture contents of each feedstuff was taken into consideration during this research. The materials used for current dropboxes were evaluated as well.

After determining the different feedstuffs used, related moisture contents, and materials, the coefficients of friction for each of the feedstuffs on different materials were determined (Brubaker and Pos, 2013). The most extreme coefficient of friction out of the given combinations of feed, moisture, and surface material (0.69 for wheat on wood float finish concrete) was used for the design

of the precision feeder to ensure that it would not be easily clogged. The corresponding most extreme angle of 34.6 degrees was used as the lower limit for design, meaning that no part of the feeder experiencing feed flow would have an angle less than the angle of repose. Setting this angle was important to reduce the potential for clogging both in the dropbox and at other locations in the feeder.



Figure 4: Compaction Testing

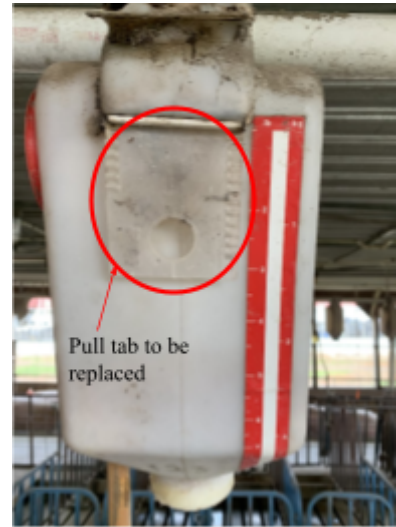
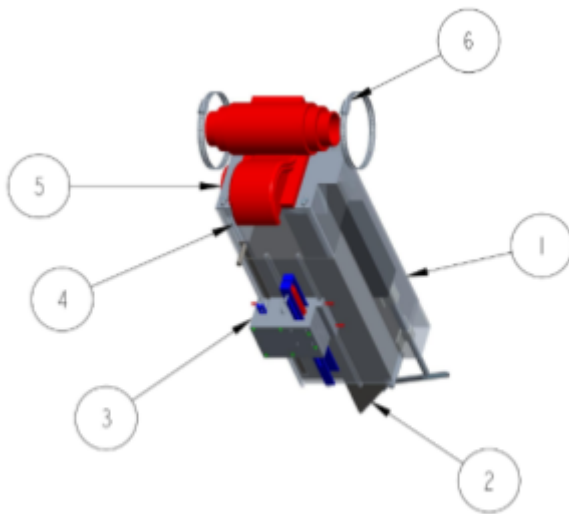

Figure 3: Current method of setting feed amount

In order to better analyze the different components of current feeders, an existing commercially available dropbox on the market from Hog Slat, Inc. was purchased, and its inner components were examined. Areas of clogging, the pull tab adjustment mechanism (figure 3), and the feeder's attachment to the auger were noted to be areas for improvement in the design of the new precision dropbox feeder.

Prior to determining the design approach that would achieve the goals and objectives of the project, aspects of the feed were further analyzed using feed from the SEU. The feed was fairly dry with roughly 20% moisture content, but still tended to clump or demonstrate cohesive properties. When the feed was put into a 25 mL graduated cylinder, it was observed that after tapping the graduated cylinder, the volume decreased significantly (figure 4). This allowed for the conclusion that a primary reason for inaccuracies in feed amounts was due to compaction.

*b. Prototype Design*



*Figure 5: Final Assembly of Mass-Based Precision Feeder*

The design of the prototype (figure 5) addresses the issues of accuracy, adjustability, and feed drop timing all while meeting the requirement of being retrofittable to existing systems. To overcome the issue of feeder inaccuracy, the design incorporates a spring system which utilizes Hooke's Law to accurately measure the weight of the feed as it enters the dropbox. This spring system also helps make the feeder easily adjustable in 0.25-lb increments by using spring displacement to determine the weight of feed supported by the springs. In order to ensure that the weight of feed is not exceeded, a trigger mechanism was designed to cut off the flow of feed immediately after the desired weight is reached. To improve the uniformity of feed drop timing across the barn, an actuator was mounted to the side of the feeder to replace

the current pull cord release. This actuator works to open and close a door at the bottom of the feeder that will allow the feed to outflow. Another actuator resets the trigger mechanism that shuts off feed flow. This is to allow the feed to refill the dropbox for the next feeding as feed is conducted through the auger.

Further testing was completed using the current feeder system where inaccuracies in the feed distribution from the auger into the plastic feeder were noted. The feed that was moved by the auger into the plastic container formed an inclined angle instead of settling at a relatively flat line, meaning that there would be a different amount of feed dispensed each time for the same feed setting. In addition to this, feed that fell into the feeder would be compacted, which resulted in inconsistencies in the actual volume of feed getting dispensed, depending on the compaction. After testing and analyzing the feed, it was decided that the best way to improve the accuracy of the feeder was to dispense feed on a weight basis instead of a volume basis. This is in contrast to the current volume based feed measuring mechanisms. To accomplish this, the box was designed as two pieces with one functioning as an outer shell, and the other containing the feed as it is dispensed. The inner box is attached to four springs of equal spring constant and equal length positioned in the top corners of the feeder. Due to limited daily cycling, spring fatigue should not impact the usefulness of the feeder. Based on the principles of Hooke's Law, the springs have

been sized with a spring constant of 0.25 lb/inch so that when four are used simultaneously, the combined spring constant is 1 lb/inch. This design decision will allow for simple adjustment of the desired feed amount, with each 0.25-lb adjustment corresponding to 0.25" spring displacement. Aluminum rods are used to attach the springs to the outer box and are sized so that the extension springs can be easily changed in the event that they become fatigued and are unable to provide an accurate measure of the feed weight.

c. Adjustment and Feed Shutoff Design

The adjustment and feed shutoff mechanism for the feeder was designed to minimize the use of electronics and maximize the use of mechanical systems to simplify any potential troubleshooting. The mechanism's design involves the application principles from mechanical hanging scales, as well as the trigger mechanism present in most foam dart guns (figure 6), and similar toys. Attached to the inner dropbox is a protruding indicator that extends through a vertical channel to the outside of the outer box, as seen in figure 7 below. As the springs extend, this indicator travels downward in the channel until it reaches a semicircular trigger which serves as its final resting place. When the indicator begins to rest on the trigger, forcing it downward, the bottom portion of the trigger transfers its vertical motion to a horizontal slider through an angled member of the trigger, as shown in figure 7. When the slider is retracted, it releases a plunger mechanism that is forced upwards by a compression spring. This plunger moves a plastic tab through the channel on the outer box's top surface, and this tab will slide over the opening that allows feed to flow into the inner box, thus stopping the flow of feed at the desired weight.



Figure 6: An example of the trigger mechanism planned to be used for the feed shut off

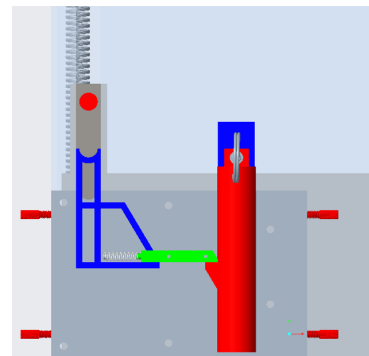

Figure 7: Creo model of trigger mechanism

The trigger, sliders, and plunger of the feed shut off mechanism are contained in a rigid plastic case that is adjustable upwards and downwards via three rails located on the outer box so that the resting height of the trigger (once the indicator has dislocated it) corresponds to the desired weight. The plastic case is set in place using four set screws on the edge of the outer channels. This is the component of the feeder that workers in the barn will be able to adjust in order for the desired weight of feed to be released to the sows.

Being that a compression spring is utilized to exert the force needed to push the plastic tab and stop the inflow of feed, it is imperative that the spring be in a compressed state prior to the inflow of feed into the dropbox. Therefore, the spring must be 'reset' to the compressed position



after each feeding cycle. In order to do this, a linear actuator has been placed axially with the compression spring and connects to the shutoff rods using a second pin with a hole a set distance from the top hole.

#### *d. Feed Release Design*

Because the inner dropbox moves independently of the outer dropbox, it was determined that the ball weight used in current feeders would be insufficient for use as a release mechanism. This is because as the feed is released, the displacement of the springs decreases and the inner dropbox moves upward towards its original position. When a ball weight is used, this upward motion causes the feed outlet to become prematurely blocked by the ball weight, not allowing the correct amount of feed to reach the sow. Therefore, it was decided that the best solution for releasing the feed would be through the use of a hinged door at the bottom of the feeder.

The hinged door is attached to an actuator that is mounted on the side of the inner dropbox. In a static state, the actuator remains fully extended holding the door closed. Because the door will be opening at a fairly slow rate of approximately 6 mm/s (0.24 in/s), the outlet of the feeder was designed to have a slanted angle. This is based upon a linear relationship that was determined between the actuator speed and the voltage the actuator receives. This design ensures that all feed enters the drop tube that leads to the trough where the sows receive their feed. Conversely, if the outlet and door were made to be parallel to the ground, as the door opens, feed would slide off of the door and be routed to areas other than the drop tube.

#### *e. Auger Connection Design*

The auger connection was designed for quick installment for various standard auger sizes. The three standard sizes for auger pipes used in this design were 2.25", 3.0" and 3.5" in diameter. The component itself is split into a top and bottom portion which is hinged together to allow the part to fit over the installed auger system. The part attaches with the use of standard hose clamps that can wrap around each side of the component once proper fitting and placement on the auger is accomplished. There are two curved channels cut into the auger connection that act as primary and secondary shutoff mechanisms. The primary shutoff mechanism is controlled by the trigger activated mechanism as previously discussed. The secondary shutoff is a manual shutoff that can be used to close off the feeder if it is not in use, or if there is a malfunction with the feeder. The goal of adding a secondary shutoff was to ensure that removing one feeder from use would still allow for the rest of the sows in the barn to be fed.

#### *f. Electrical Components*

According to the manufacturer spec sheet, the actuator chosen has a stroke length of 100 mm, a speed of 8 mm/s, and a force of 70 N (3.9 in, 0.31 in/s, 15.7 pounds respectively). The stroke length provides the full range of motion needed to open and close the door, and the force is sufficient to open the door and keep it tightly closed as feed fills the box and adds weight on the door. Further, the actuator chosen has the necessary force required to reset the compression

spring in the trigger system to a compressed state. Each actuator was wired to be controlled by a push button, which would promote a user-friendly design. In regard to wiring and coding, each actuator requires the use of an Arduino, a two channel relay, a battery power source, and a push button. A diagram demonstrating the circuitry is displayed in figure 8. Each actuator is to extend and retract with specific time intervals. In order to implement this, a code that utilized an ‘if-else’ statement, along with ‘digitalWrite’ and ‘delay’ functions was uploaded to the Arduino Uno. The ‘if-else’ statement was used to send a signal to the Arduino Uno denoting whether the push button was in an open or closed state. Then, based on whether or not the corresponding pin connected to the push button was reading high or low, pins that were connected to the relay were written as high or low. This aspect of the circuitry allowed control over the actuator’s extension and retraction, or held it stationary. The power’s polarity, which was transmitted from the battery to the actuator, was reversed utilizing the relay.

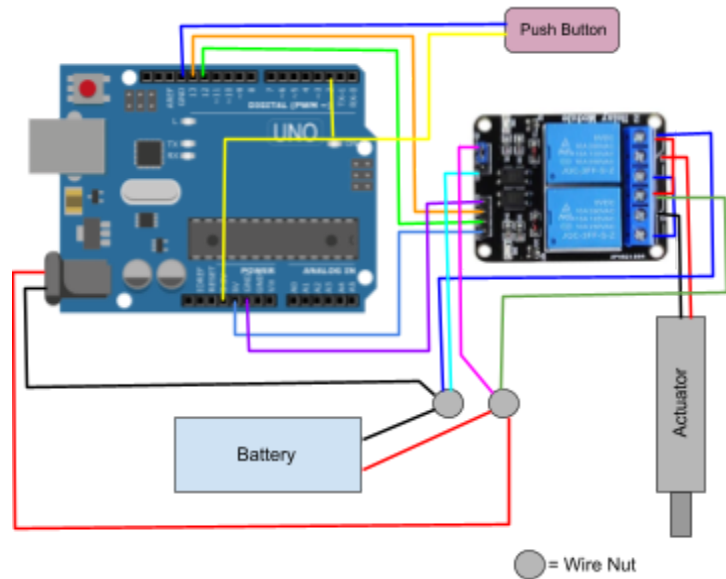

Figure 8: Wiring diagram depicts how Arduino Uno is connected to relay, battery, push button, and actuator

#### g. Similarities to Existing Feeders

Apart from newly designed aspects of the feeder, it is important to note that some parts of the existing feeder were kept the same due to their well engineered functionality. At the bottom of the feeder, the angles leading to the outlet required no alteration to their geometry, but only needed to be resized to fit within the outer box. This is because the angle of the bottom is well beyond that of any feedstuff’s angle of repose (34.6 degrees), so clogging was not an issue. Another notable unchanged feature is the cleanout hole, as seen in Drawing 2 (Sheet No. A100\_2) in the Appendix, which was useful for troubleshooting any issues that arose on the inside of the outer dropbox.

#### h. Materials

Various tests were done during the design process to ensure the design was feasible and usable. Different materials were tested in an effort to see what material would slide with the most ease across the surface of a PLA 3D printed part. The trigger casing was 3D printed using PLA. This was deemed the most viable material option and fabrication method due to the precision inner working parts that could not be easily fabricated using aluminum or stainless steel. The trigger needed to easily slide in the channel provided within the trigger casing. Therefore, a variety of trigger materials were explored. The first trigger was fabricated out of aluminum. The major advantage of aluminum was that it would be durable. However, during testing it was discovered

that the aluminum and PLA materials did not slide easily against each other, and it was determined that the aluminum material would cause issues during normal use. The second option was to fabricate the piece by 3D printing using PLA. When this material was tested, there was much less friction between the trigger and the casing, so it was deemed suitable. The PLA trigger did not experience any limitations and was able to move fairly smoothly through the channel. Therefore, this material was chosen for the major sliding parts within the design.

*i. Calibration*

In preparation for calibration, the feeder was positioned in a manner in which it was level and the inner dropbox would displace along a vertical axis with limited contact with the outer dropbox. To calibrate the precision feeder prototype, displacement of the indicator was measured and marked along the indicator channel of the outer dropbox for 0.25-lb increments ranging from 5.00 to 7.25 lb. The feed was a corn-soybean meal provided by the SEU. A baseline distance traveled by the inner dropbox for 5 lb of feed was first determined. This was done by weighing 5 lb of feed and adding that quantity to the feeder. This displacement was then used for all successive measurements. Then, 0.25-lb increments of feed were added to the feeder and the displacement of the indicator was marked along the channel for these measurements as well. The actuator timing had to be calibrated based on how long it took the feed to drop out of the box.

**IV. Budget and Bill of Materials**

The total cost for the design and prototyping process equated to approximately \$1,550. However, it is estimated that the cost of a feeder, if mass produced, would be approximately \$50 based upon the following assumptions. The total fabrication cost took into consideration parts that were later deemed unsuitable for the design, as well as the labor hours. Labor was the primary driver in the budget, equating to \$1,260. Additionally, the purchase of the pre-existing feeder used for reverse engineering purposes was approximately \$50. Materials

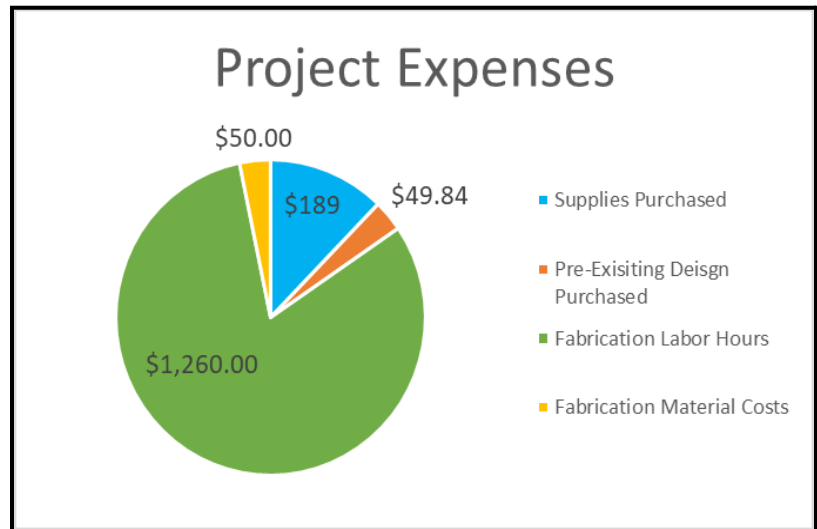

*Figure 9: Costs Summary*

purchased for fabrication of the prototype contributed to the remaining portion of the budget. It is important to note that the design process consisted of experimental aspects, which significantly prolonged the fabrication timeframe. Additionally, the materials used for the larger components of the feeder, including the inner and outer dropbox, were fabricated using stainless steel; a material that is more expensive to obtain and work with. If the design were to be mass produced, the cost of fabrication would significantly decrease. It is likely that in the case of mass production numerous feeders would be fabricated in a day, reducing the overall labor costs.

Additionally, using blow molded plastic as opposed to stainless steel would also significantly decrease the overall fabrication cost.

## V. Design Testing and Future Considerations

### a. Analysis of Precision and Accuracy of Feeder

For analysis on the efficacy of the precision feeder prototype, two cycles of tests for a current feeder on the market (Chore-Time), and two cycles of tests for the new prototype were completed. A selected range of 5.00 to 7.25 lb at 0.25-lb increments was selected for testing purposes, as the typical range of feed weights for sows ranges from 4 to 7 lb. For the Chore-Time feeder, the corn-soybean meal provided by NC State’s SEU was used to fill the feeder to each incremental weight value according to the weight markings denoted on the pull tab. The feed was then released into a bucket and weighed to compare the error between the weight the feeder was set to and the weight of feed that would actually be received by the sow. The process was completed twice for each 0.25-lb increment for a total of 20 measurements. As for the prototype feeder, the same increments of feed weights were added to the feeder and the displacement of the indicator was observed. Two cycles and 20 total measurements were performed. The measured distances are reported in Table 1, which were then converted to lb of feed in the dropbox based on this travel distance. An equation was developed to create a linear relationship between distance and weight:

$$Weight = 5 + n[(Weight\ at\ Measured\ 7.25\ lbs - Weight\ at\ Measured\ 5\ lbs)/9]$$

The two trials for each feeder were averaged for both the Chore-Time and prototype feeder, which were subsequently plotted against each other in figures 10 and 11. Figure 10 displays the actual feed within the feeders against desired weight, while figure 11 displays the percent error from the desired feed weight.

<b>Table 1: Prototype Inner Box Travel Distance Testing (Inches)</b>		
<b>1</b>	<b>2</b>	<b>Average</b>
4.13	4.13	4.13
4.25	4.38	4.31
4.50	4.63	4.56
4.75	4.88	4.81
5.00	5.00	5.00
5.25	5.13	5.19
5.38	5.50	5.44
5.75	5.75	5.75
6.00	6.00	6.00
6.25	6.38	6.31

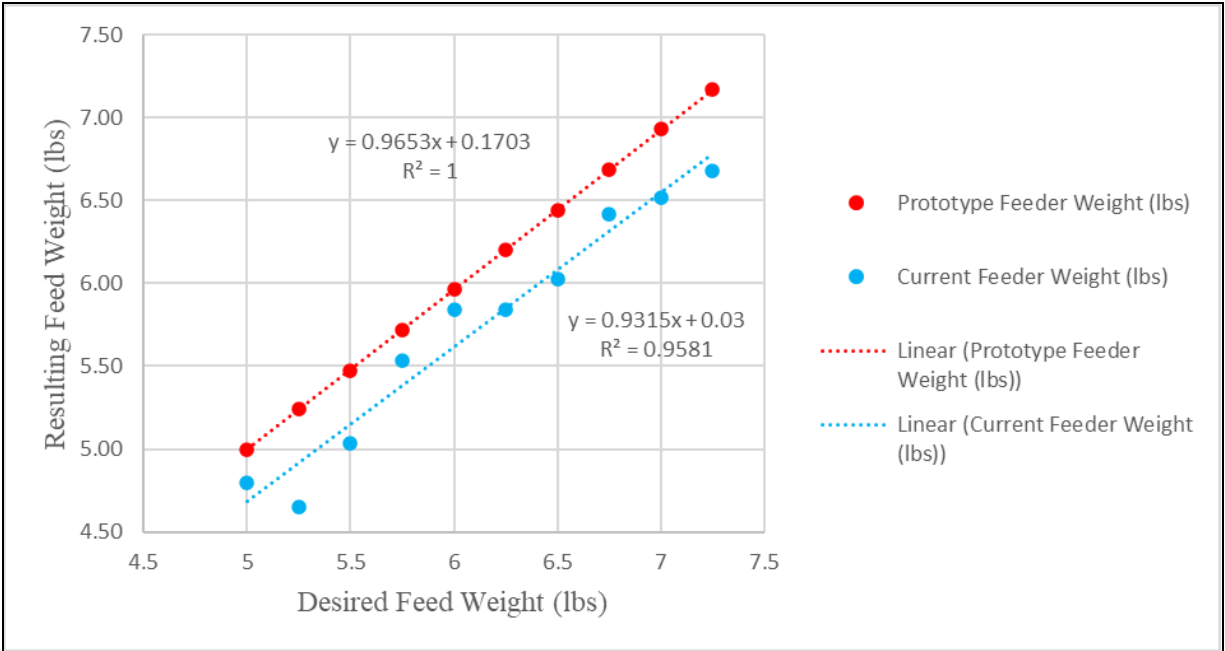

Figure 10: Average Feed Distribution in Current and Prototype Sow Feeders

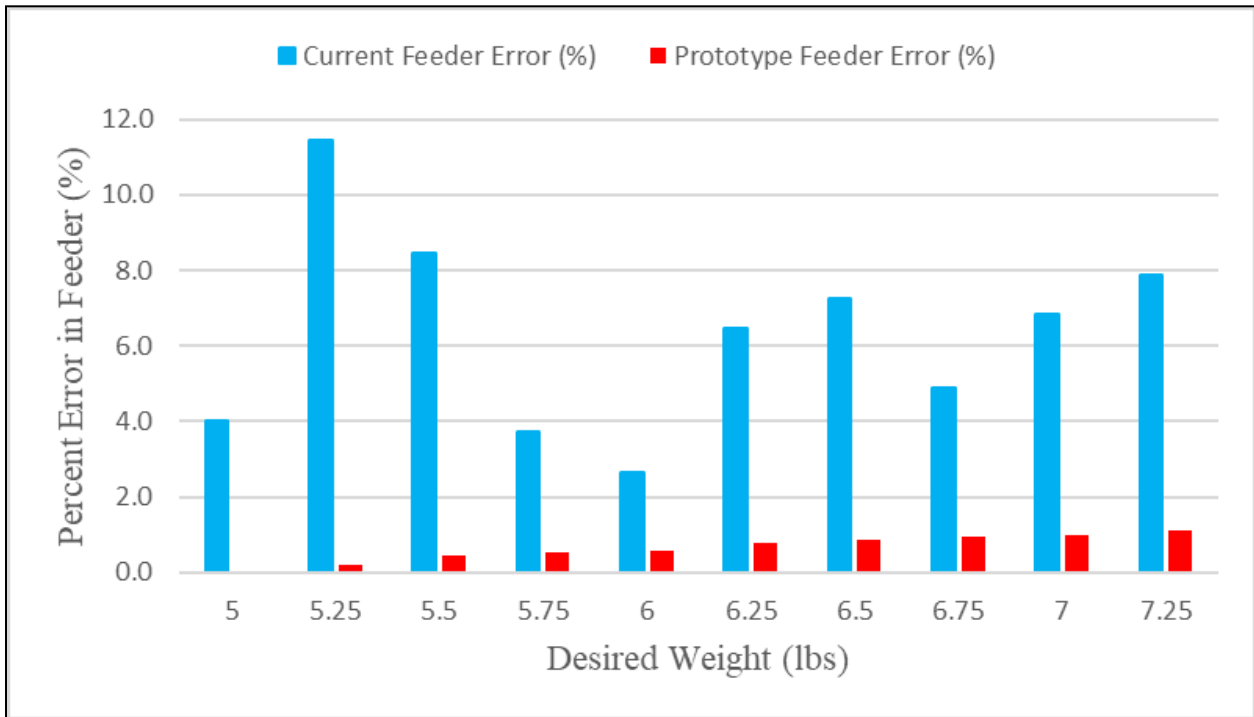

Figure 11: Percent Error in Current Prototype Sow Feeders

On average, the prototype feeder deviated from the desired weight by 0.3 lb (5%) less than the existing feeder. Using this information, the annual feed cost savings was calculated based on the

cost of feed and the number of sows on a given farm. Using data provided by *NC Farm House* and the *NC Cooperative Extension*, feed costs for sows was approximately \$0.22/lb. Given that annual feed days are around 300 days for sows and a base number of 1000 pigs was chosen, the average daily savings was estimated as potentially \$396 and average annual savings was \$118,800 (Table 2).

<b>Table 2: Feed Savings for 1000 Sows (Estimated for 250 lb sows)</b>	
Feed Costs	\$0.22/lb
Number of Sows	1000 sows
Average Feed Savings	0.3 lbs
Average Feed Given Per Day	6 lbs/day
Feed Savings Per Day	\$396
Feed Savings Per Year	\$118,800

b. Future Considerations

Throughout the testing process, future design alterations were taken into consideration. The first limitation of the current design is the source of power for the linear actuators. Due to the confined space and wiring placement, the current prototype presents some issues in regard to a maintained power source. The 9-V batteries are capable of powering the actuator, but are very short-lived due to the lack of a constant amperage. Therefore, in the future it would be beneficial to connect the feeders to an electrical line that would provide a constant power source throughout the feeder’s lifecycle. While changing the batteries is not extremely difficult in the prototype design, it would not be ideal to have to change the batteries as frequently as what would be required. This would require advice from an electrical engineer/technician to gain a better perspective of the most economical and feasible approach that would prove to be both safe and ensure the longevity of the system. Further, the material of the feeder would ideally be primarily blow molded plastic, which would reduce the overall weight of the feeder, as well as minimize the fabrication cost if the feeder were mass produced.

Another issue that could benefit from further design improvements is the shutoff mechanism. The plastic tab associated with the shutoff experiences some friction, which is partially due to the manner by which the auger connection had to be 3D printed. In order to have the ability to remove support material, the auger connection had to be printed as two halves, instead of one whole piece. It would be beneficial to utilize a linear bearing to maintain a linear motion and reduce friction as the plastic tab slides through the channel. Additionally, the alignment of the inner dropbox still posed to be a slight issue due to friction. The connection points for the four extension springs that the inner dropbox is suspended from had to be designed so that the springs could be easily changed as they fatigue over time. However, as a result the design does not allow the extension springs to be constrained along a specific axis or channel, so it is highly likely that the inner box will contact the outer dropbox at some point as feed is flowing into it. Depending on the duration of contact, this can cause inaccuracies in the precision of the performance of the

feeder. Linear bearings or teflon wear strips mounted to the inner surface of the outer box would be a likely solution to this issue for future prototypes.

Moreover, it would also be beneficial to fabricate multiple feeders to test on a larger scale. During this testing, the implications of sow welfare, in addition to the functionality of the feeder would be observed and analyzed. This information would be valuable in determining further improvements that could be made to the design.

## **VI. Conclusions**

The current state of sow feeders is high in variability and imprecise in measurement. The objective of this project was to design a feeder with increased precision while being relatively inexpensive and retrofittable to current barns. A new feeder was designed which implemented a weight-based measurement system, in comparison to the traditional volume-based system used in existing feeders. A mock scale system which utilized principles of spring displacement is used to measure the feed as it enters the feeder. Further, a trigger assembly is utilized to stop the inflow of feed into the feeder when the desired weight is reached. Overall, this design solved the problem of high variability in feed measurements in current sow feeders while maintaining its ability to be retrofittable. However, the design solution was accompanied by challenges to consider for future design amendments. The use of electronics to run the feed door and trigger assembly reset may not be ideal in the harsh environment of the gestation barn. The barn environment may deteriorate different electrical components even if installed in a protective enclosure. The bulk of the larger components, such as the inner and outer dropboxes, were made of aluminum. This material proved to be much heavier than necessary and difficult to install. The 3D printed parts were too weak for the forces induced by the design and would not have an acceptable duration in the scope of a more permanent application. While these things did cause substantial issues during the prototyping process, all of them could be resolved with mass fabrication of parts from blow formed plastic and industrial grade electronic casing and components.

## VII. References

J. E. Brubaker, J. E. and J. Pos. (1965). Determining static coefficients of friction of grains on structural surfaces. *Transactions of the ASAE*, 8(1), 53–0055.  
<https://doi.org/10.13031/2013.40423>

Carlson, Marcia. “Swine Diet Manipulation to Minimize Environmental Impacts.”  
*University of Missouri Extension*, Nov. 2018,  
<https://extension.missouri.edu/publications/g2324>.

Econo Drop Feeder. (n.d.). Retrieved September 29, 2022, from  
[https://www.automatedproduction.com/en\\_US/ap-products/feeding/feed-and-watering/drop-feeders/econo-drop-feeder.html](https://www.automatedproduction.com/en_US/ap-products/feeding/feed-and-watering/drop-feeders/econo-drop-feeder.html)

Gaillard, C., & Dourmad, J.-Y. (2022). Application of a precision feeding strategy for gestating sows. *Animal Feed Science and Technology*, 287, 115280.  
<https://doi.org/10.1016/j.anifeedsci.2022.115280>

Li YZ;Cui SQ;Yang XJ;Johnston LJ;Baidoo SK; (2018). *Minimal floor space allowance for gestating sows kept in pens with electronic sow feeders on fully slatted floors*. Journal of animal science. Retrieved September 13, 2022, from  
<https://pubmed.ncbi.nlm.nih.gov/30032239/>

Thomas L, Gonçalves M, Vier C, et al. Lessons learned from managing electronic sow feeders and collecting weights of gestating sows housed on a large commercial farm. *J Swine Health Prod*. 2018;26(5):270-275.

Vargovic, L., Hermes, S., Athorn, R. Z., & Bunter, K. L. (2021, January 1). *Feed intake and feeding behavior traits for gestating sows recorded using electronic sow feeders*. Journal of animal science. Retrieved September 13, 2022, from  
<https://www.ncbi.nlm.nih.gov/pmc/articles/PMC7799585/>



### VIII. Appendix A: Drawings

Index	Description	Component Type	Qty
1	A1_OUTER_DROPBOX	ASSEMBLY	1
2	A2_INNER_DROPBOX	ASSEMBLY	1
3	A3_SHUTOFF_ASSEMBLY	ASSEMBLY	1
4	A4_EXTENSION_SPRING	ASSEMBLY	4
5	A5_RED_SIDE_CAP	PART	1
6	A6_HOSE_CLAMP	ASSEMBLY	2

<b>Bio &amp; Ag Eng.</b> <b>BAE 452, Spring 2023</b> <b>Raleigh, NC</b>	<small>UNLESS OTHERWISE SPECIFIED,          DIMENSIONS ARE IN INCHES.          TOLERANCES ARE:          .X ± .05      ANGLES: ±0.1°          .XX ± .005</small>	Assembly Drawing		
		Drwn By: JMR		A100_PRECISION_SOW
		Date: Apr-11-23	Scale: 0.125	Sheet No. A100

  

<b>Bio &amp; Ag Eng.</b> <b>BAE 452, Spring 2023</b> <b>Raleigh, NC</b>	<small>UNLESS OTHERWISE SPECIFIED,          DIMENSIONS ARE IN INCHES.          TOLERANCES ARE:          .X ± .05      ANGLES: ±0.1°          .XX ± .005</small>	Assembly Drawing		
		Drwn By: JMR		A100_PRECISION_SOW
		Date: Apr-11-23	Scale: 0.250	Sheet No. A100_2



- Hinge Connects the Top and Bottom Auger Connection Components.

- Feedplate is contained within the outer drop box

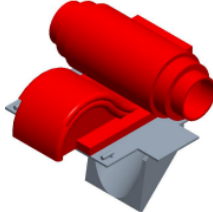

<b>Bio &amp; Ag Eng.</b> <b>BAE 452, Spring 2023</b> <b>Raleigh, NC</b>	<small>UNLESS OTHERWISE SPECIFIED,          DIMENSIONS ARE IN INCHES.          TOLERANCES ARE:          .X ± .05      ANGLES: ±0.1°          .XX ± .005</small>	Assembly Drawing	A1_OUTER_DROPBOX	
		Drwn By: JMR		
		Date: Apr-11-23	Scale: 0.188	Sheet No. A1_2

Index	Description	Component Type	Qty
1	C1_INNERDB	PART	1
2	C2_B_ACTUATOR HOLDER	PART	1
3	C3_HINGE	ASSEMBLY	1
4	C4_FEED_DOOR	PART	1
5	C5_T_ACTUATOR HOLDER	PART	1
6	C6_ACTUATOR_BASE	PART	1
7	C7_ACTUATOR_ARM	PART	1
8	C8_SLIDER_PIN	PART	1
9	C9_ELECTRONICS_CASING	PART	2

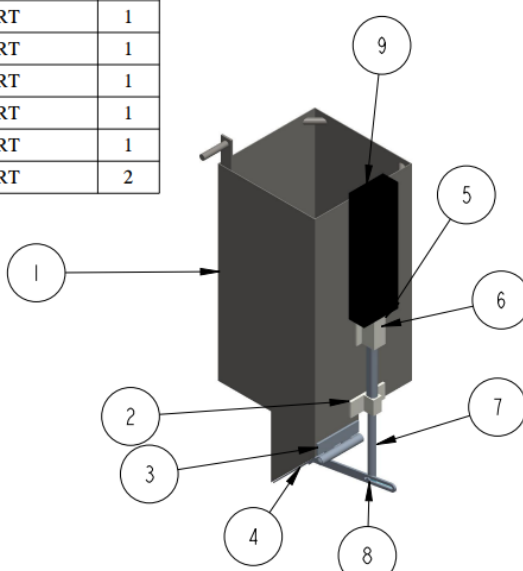

<b>Bio &amp; Ag Eng.</b> <b>BAE 452, Spring 2023</b> <b>Raleigh, NC</b>	<small>UNLESS OTHERWISE SPECIFIED,          DIMENSIONS ARE IN INCHES.          TOLERANCES ARE:          .X ± .05      ANGLES: ±0.1°          .XX ± .005</small>	Assembly Drawing	A2_INNER_DROPBOX	
		Drwn By: JMR		
		Date: Apr-11-23	Scale: 0.188	Sheet No. A2

Index	Description	Component Type	Qty
1	D1_TRIGGER_CASING_1	PART	1
2	D10_TRIGGER_SLIDER_BACK	PART	1
3	D11_TRIGGER_SLIDER_FRONT	PART	1
4	D12_TRIGGER_SPRING	PART	2
5	D13_THUMB_SCREW	PART	4
6	D14_225_BOLT	PART	2
7	D15_2125_BOLT	PART	4
8	D2_EXOSLIDE20	ASSEMBLY	2
9	D3_TRIGGER_CASING_2	PART	1
10	D4_COMP_SPRING_ASSEMBLY	ASSEMBLY	1
11	D5_QUICK_PIN	ASSEMBLY	1
12	D6_SHUTOFF_ROD	PART	2
13	D7_TRIGGER_CASING_3	PART	1
14	D8_TRIGGER_CASING_4	PART	1
15	D9_TRIGGER	PART	1

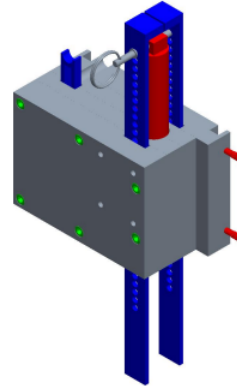

<b>Bio &amp; Ag Eng.</b> <b>BAE 452, Spring 2023</b> <b>Raleigh, NC</b>	UNLESS OTHERWISE SPECIFIED, DIMENSIONS ARE IN INCHES. TOLERANCES ARE: .X ± .05      ANGLES: ±0.1° .XX ± .005	Assembly Drawing	A3_SHUTOFF_ASSEMBLY	
		Drwn By: JMR	Scale: 0.375	Sheet No. A3
		Date: Apr-11-23		

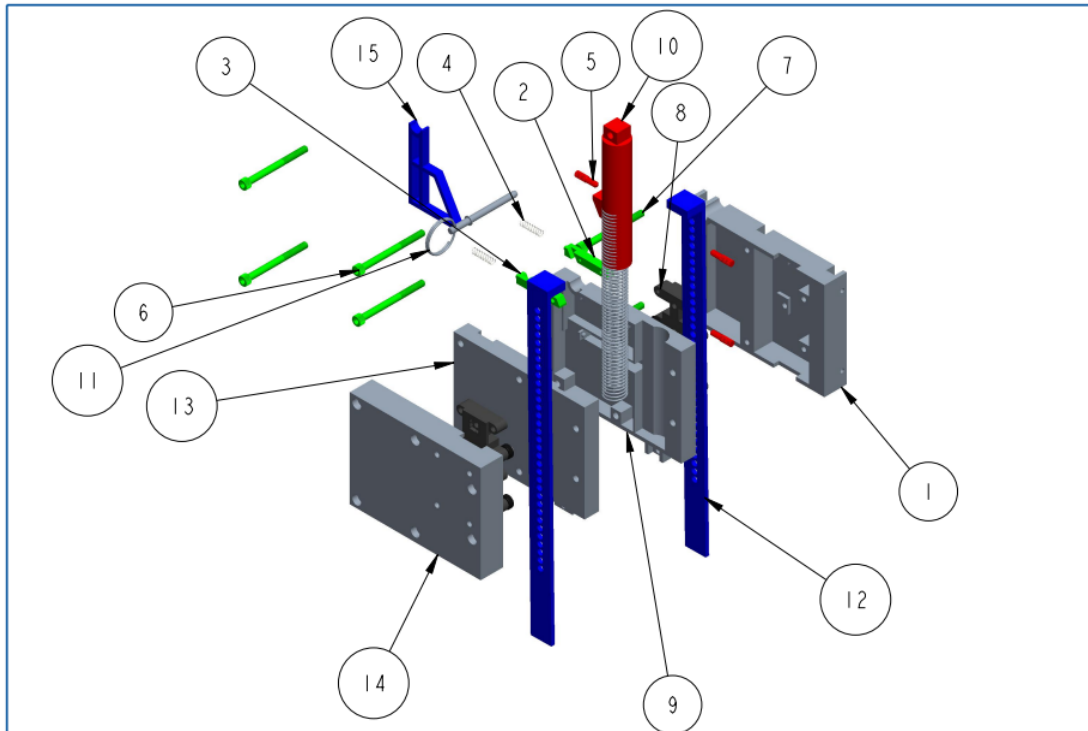

<b>Bio &amp; Ag Eng.</b> <b>BAE 452, Spring 2023</b> <b>Raleigh, NC</b>	UNLESS OTHERWISE SPECIFIED, DIMENSIONS ARE IN INCHES. TOLERANCES ARE: .X ± .05      ANGLES: ±0.1° .XX ± .005	Assembly Drawing	A3_SHUTOFF_ASSEMBLY	
		Drwn By: JMR	Scale: 0.375	Sheet No. A3_2
		Date: Apr-11-23		

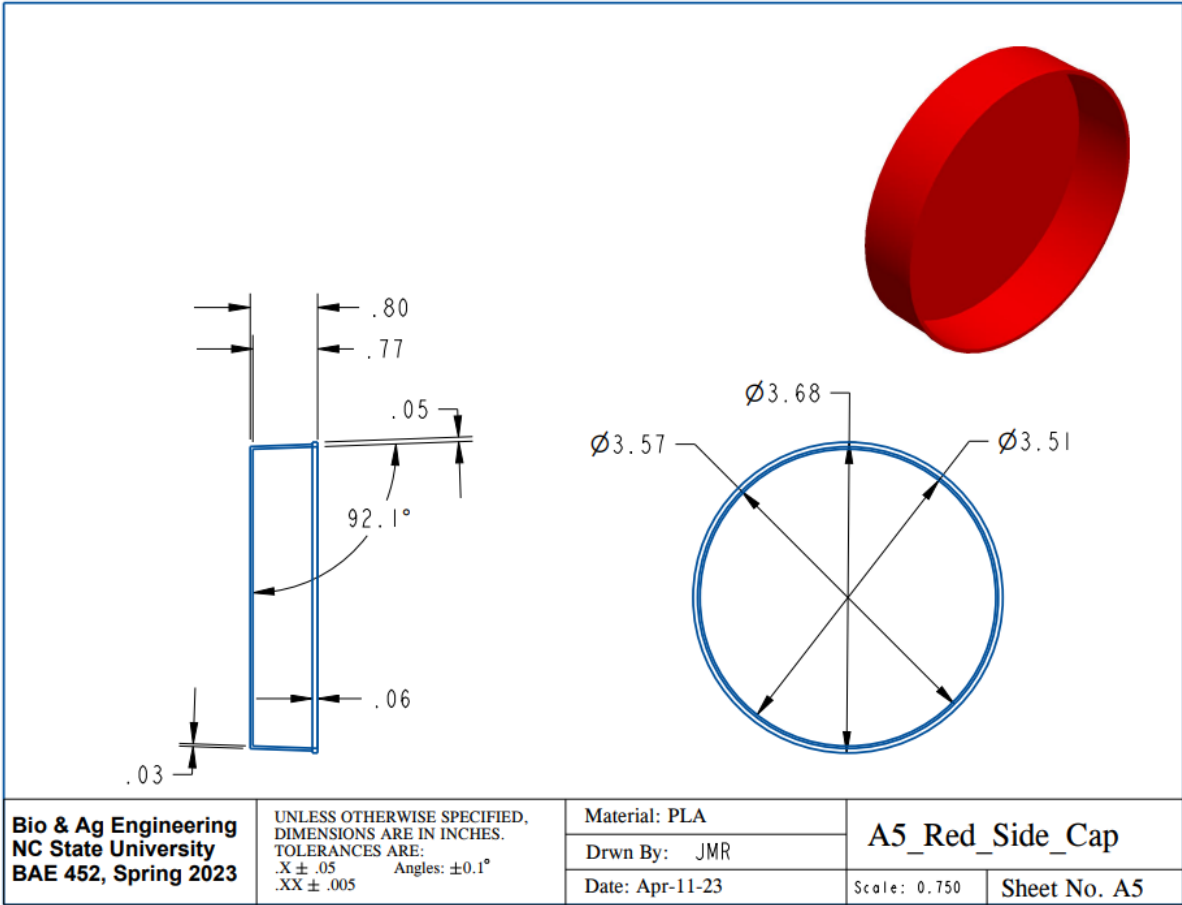

## IX. Appendix B: Bill of Materials

Line	Level	Part Name	Drawing #	Manufacturer's Part #	Qty	Bought/Made	Material	Total Price
1	1	Complete Assembly	A100			1 M		0
2	2	Outer_Dropbox	A1			1 M		0
3	3	OuterDB	B1			1 M	Aluminum	0
4	3	ODD_Top	B2			1 M	Aluminum	0
5	3	B_Auger_Conn	B3			1 M	PLA	0
6	3	Feed_Plate	B4			1 M	PLA	0
7	3	Hinge	B5	McMaster-Carr 1603A7		1 B	Brass	\$4.54
8	3	T_Auger_Conn	B6			1 M	PLA	0
9	2	Inner_Dropbox	A2			1 M		0
10	3	InnerDB	C1			1 M	Aluminum	0
11	3	B_Actuator_Holder	C2			1 M	PLA	0
12	3	Hinge	C3	McMaster-Carr 1609A25		1 B	Aluminum	\$7.96
13	3	Feed_Door	C4			1 M	Aluminum	0
14	3	T_Actuator_Holder	C5			1 M	PLA	0
15	3	Actuator_Base	C6	Amazon BTER B09KY141Q7		2 B		\$58
16	3	Actuator_Arm	C7			2 B		0
17	3	Slider_Pin	C8			1 M	PLA	0
18	3	Electronics_Casing	C9			2 M	PLA	0
19	2	Shutoff_Assembly	A3			1 M		0
20	3	Trigger_Casing_1	D1			1 M	PLA	0
21	3	Exoslide20	D2	EXOSLIDE LLC EXOSLIDE 20		2 B		\$17.90
22	3	Trigger_Casing_2	D3			1 M	PLA	0
23	3	Comp_Spring_Assembly	D4			1 M		0
24	3	Quick_Pin	D5	McMaster-Carr 98470A014		1 B	Stainless Steel	\$3.45
25	3	Shutoff_Rod	D6			2 M	PLA	0
26	3	Trigger_Casing_3	D7			1 M	PLA	0
27	3	Trigger_Casing_4	D8			1 M	PLA	0
28	3	Trigger	D9			1 M	PLA	0
29	3	Trigger_Slider_Back	D10			1 M	PLA	0
30	3	Trigger_Slider_Front	D11			1 M	PLA	0
31	3	Trigger_Spring	D12	McMaster-Carr 9435K22		2 B	Stainless Steel	\$13.40
32	3	Thumb_Screw	D13	McMaster-Carr 91746A218		4 B	Stainless Steel	\$5.54
33	3	225_Bolt	D14	McMaster-Carr 92196A280		2 B	Stainless Steel	\$8.97
34	3	2125_Bolt	D15	McMaster-Carr 90696A186		4 B	Stainless Steel	\$10.00
35	2	Extension_Spring	A4	McMaster-Carr 9433K909		4 B	Stainless Steel	\$17.60
36	2	Red Side Cap	A5	Chore-Time #30361-1		1 B	Plastic	\$5
37	2	Hose Clamp	A6	McMaster-Carr 5416K35		2 B	Stainless Steel	\$15.35
38	4	Arduino Uno	-	Amazon A000066		2 B		\$28.50
39	4	Relay	-	Amazon WMYCONGCONG RELAY 1248		2 B		\$10.99
40	4	9V Battery	-	Amazon 6LR1		3 B		\$12.99
41	4	Push Button	-	Grainger 10C567		2 B		\$6.63
							Total	\$226.82

## X. Appendix C: Arduino Code

### Door Code

```
const int buttonPin = 2;
int buttonState = 0;

void setup() {
  // put your setup code here, to run once:

  //Push Button

  // Serial.begin(9600);
  pinMode(buttonPin,INPUT);
  pinMode(12,OUTPUT);
  pinMode(13,OUTPUT);
  digitalWrite(2, LOW);
}

void loop() {
  buttonState = digitalRead(buttonPin);
  if(buttonState == HIGH) {

    digitalWrite(12,HIGH);
    digitalWrite(13,LOW);

    delay(6000);

    digitalWrite(12,HIGH);
    digitalWrite(13,HIGH);

    delay (6000);

    digitalWrite(12,LOW);
    digitalWrite(13,HIGH);

    delay (6000);

    digitalWrite(12, LOW);
    digitalWrite(13, LOW);

    delay (6000);
```

```
  }
  // } else {

  // digitalWrite(12,LOW);
  //digitalWrite(13,HIGH);

  //delay (6000);

  //delay(10000);
  // }
  // }

//NEW SECTION

// } else{
//digitalWrite(12,LOW);
//digitalWrite(13,HIGH);
// }
//delay(20000);
//exit(0);
//}
//}
//else {
//digitalWrite(12,0);
//digitalWrite(13,0);
// }

//digitalWrite(12,HIGH);
//digitalWrite(13,HIGH);

//delay(2000);
//digitalWrite(2,LOW);}
//else {
//}
//}
//}
```

Ln 2, Col 25

### Shutoff Code

```
const int buttonPin = 2;
int buttonState = 0;

void setup() {
  // put your setup code here, to run once:

  //Push Button

  // Serial.begin(9600);
  pinMode(buttonPin,INPUT);
  pinMode(12,OUTPUT);
  pinMode(13,OUTPUT);
  //digitalRead(2);
}

void loop() {
  buttonState = digitalRead(buttonPin);
  if(buttonState == HIGH) {

    digitalWrite(12,HIGH);
    digitalWrite(13,LOW);

    delay(13758);

    digitalWrite(12,HIGH);
    digitalWrite(13,HIGH);

    delay (6000);

    digitalWrite(12,LOW);
    digitalWrite(13,HIGH);

    delay (20000);

    digitalWrite(12, LOW);
    digitalWrite(13, LOW);

    delay (6000);
```

```
  }
  // } else {

  // digitalWrite(12,LOW);
  //digitalWrite(13,HIGH);

  //delay (6000);

  //delay(10000);
  // }
  // }

//NEW SECTION

// } else{
//digitalWrite(12,LOW);
//digitalWrite(13,HIGH);
// }
//delay(20000);
//exit(0);
//}
//}
//else {
//digitalWrite(12,0);
//digitalWrite(13,0);
// }

//digitalWrite(12,HIGH);
//digitalWrite(13,HIGH);

//delay(2000);
//digitalWrite(2,LOW);}
//else {
//}
//}
//}
```